

FSM4000

Electromagnetic Flowmeter

The all-purpose flowmeter
for conductive fluids



Function

- Electromagnetic flowmeters can be used to accurately measure the flowrate of liquids, slurries, pastes and sludges with an electrical conductivity of at least 20 $\mu\text{S}/\text{cm}$ (opt. 5/0.5 $\mu\text{S}/\text{cm}$).

Applications

- The system is specially designed to measure liquids in the pulp & paper and food & beverage industries. It can be used to measure fast changing processes, two phase liquids, continuous and pulsating flows (piston pump application).

Benefits

- Digital signal processing (DSP) and zero stability ensure long-term stability and accuracy in both flow directions.
- Enhanced diagnostic functions and monitoring of coil and electrode circuits as well as magnetic field for increased operational stability. Verification via fingerprint.

Key features

- Pressure equipment designed acc. to PED Directive 97/23 EC
- Meter size DN 1 ... DN 1000 (1/25 ... 40")
- Accuracy $< \pm 0.5\%$ of rate ($> \text{DN } 2$)
- Fluid temperature $-40 \dots 130 \text{ }^\circ\text{C}$ ($-40 \dots 266 \text{ }^\circ\text{F}$) (opt. $180 \text{ }^\circ\text{C}$ [$356 \text{ }^\circ\text{F}$])
- Hygienic certification: 3A, EHEDG
- Liners, PFA, PTFE, ETFE, hard or soft rubber, ceramic carbide
- Standardized installation lengths for DIN, ASME B16.5 or JIS B2210-10K flanges
- AC / DC supply power

Contents

1 Overview of flowmeter sensor and transmitter designs3

2 General information4

 2.1 Measuring accuracy4

 2.2 Grounding4

 2.3 Installation Requirements4

 2.4 Flowmeter Sizes, Pressure Ratings, Flow Range7

 2.5 Flowrate nomograph9

3 Model SE41F10

 3.1 Specifications10

 3.2 Dimensions13

 3.3 Ordering information22

4 Model SE21_32

 4.1 Specifications32

 4.2 Dimensions34

 4.3 Ordering information45

5 Mounting accessories52

 5.1 Ordering information Wafer Accessories (Table H)53

6 Transmitter54

 6.1 Specifications54

 6.2 Inputs/outputs56

 6.3 Digital communication56

 6.4 Electrical connections58

 6.5 Connection examples for peripherals (incl. HART)62

 6.6 Dimensions65

 6.7 Ordering information66

 6.8 FXC4000 flowmeter sensor simulator67

 6.9 Installation set for 2" pipe installation in field-mount housing67

1 Overview of flowmeter sensor and transmitter designs

Housing Material	Alu. Housing, Series 4000		Stainless Steel Housing, Series 2000			
	Fixed Flange		Fixed Flange		Variable Connections	
Flowmeter sensor	SE41F		SE21F		SE21W	
Model number	SE41F		SE21F		SE21W	
Measured value error	0.5% of rate (> DN 2)					
	DN	PN	DN	PN	DN	PN *
Wafer type	-		-		3 ... 50 65 ... 100	10 ... 40 10 ... 16
Flange DIN 2501/EN 1092-1	3 ... 1000	10 ... 40	3 ... 100		10 ... 40	-
Flange ASME B16.5 / B16.47 JIS B2210-10K	1/10 ... 40" 1/10 ... 12"	CL 150 CL 300	1/10" ... 4" 1/10" ... 4"	CL150 ... CL300/JIS	1/10" ... 2" 3" ... 4"	CL300/JIS CL150/JIS
Pipe connection DIN 11851	-		-		-	
Weld stubs DIN 11850	-		-		-	
Weld stubs DIN 2463 / ISO 1127	-		-		-	
Weld stubs ISO 2037 / SMS	-		-		-	
Tri-clamp DIN 32676 / ASME BPE	-		-		-	
External threads ISO 228 / DIN 2999	-		-		-	
1/8" sanitary connectors	-		-		-	
Lining	Hard/soft rubber, ceramic carbide, PTFE, PFA, ETFE, other		PFA (vacuum-tight)		PEEK, Torton (< DN 3) PFA (> DN 2)	
Conductivity	≥ 20 µS/cm (optional ≥ 5/0.5 µS/cm)					
Electrodes	Stainless steel 1.4571 (316 Ti), 1.4539 (904 L), Hastelloy B-3/C-4, platinum-iridium, tantalum, titanium					
Process Connection Material	Steel, stainless steel		-		> DN 2: Stainless steel 1.4404 (316 L) < DN 3: 1.4571 (316 Ti), PVC, POM	
Degree of protection acc. to EN 60529	IP 65 / IP 67 / IP 68		IP 65 / IP 67 / IP 68		IP 65 / IP 67 / IP 68	
Fluid temperature	-25 ... 130 °C / 180 °C -13 ... 266 °F / 356 °F		-25 ... 130 °C -13 ... 266 °F		-40 ... 130 °C -40 ... 266 °F	
Approvals						
Hygienic and sterile requirements	-		CIP/SIP-enabled		3A, EHEDG, CIP/SIP-enabled	
Pressure Equipment Directive 97/23/EC	Conformity assessment in accordance with category III, fluid group 1					
CRN (Canadian Reg. Number)	On request					
Transmitter						
Model number	S4					
Supply power	85 ... 253 V AC, 24 V AC/DC					
Current output	0/2 ... 10 mA, 0/4 ... 20 mA					
Impulse output	active (24 V), optocoupler (220 mA)					
Ext. zero return	yes					
Ext. totalizer reset	yes					
Forward/reverse flow metering	yes					
Communication	HART protocol, PROFIBUS PA, FOUNDATION Fieldbus					
Pipe empty detection std.	yes, DN 10 or higher and ≥ 20 µS/cm					
Self-monitoring, extended diagnostic functions	yes, expanded diagnostic functions / fingerprint only in connection with flowmeters SE21, SE21F and SE41F for DN 10 or higher					
On-site display/totalization	yes					
Density correction	yes, manual entry (totalize and display in mass units)					
Degree of protection acc. to EN 60529	IP 65 / IP 67, NEMA 4X					
Housing	field-mount housing					

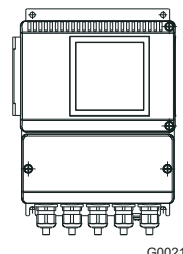

G00212

1) Weld stubs 2) Tri-clamp 3) Threaded pipe connection 4) External threads

2 General information

2.1 Measuring accuracy

2.1.1 Reference conditions per EN 29104

Fluid temperature	20 °C (68 °F) ± 2 K
Ambient temperature	20 °C (68 °F) ± 2 K
Power supply	Line voltage as per name plate $U_N \pm 1\%$
Installation conditions	<ul style="list-style-type: none"> – Upstream > 10 x DN straight section – Downstream > 5 x DN straight section DN = Flowmeter sensor size
Warm-up phase	30 min

2.1.2 Maximum measuring error

Pulse output

- DN 1 ... DN 2 (1/25 ... 1/12"): ± 1% of measured value, ± 0.001 Q_{maxDN}
- DN 3 ... DN 1000 (1/10 ... 40"): $Q > 0.05 Q_{maxDN} \pm 0.5\%$ of measured value
- $Q < 0.05 Q_{maxDN} \pm 0.00025 Q_{maxDN}$

Q_{maxDN} = maximum flowrate for the flowmeter size 10 m/s

Analog output effects

Same as pulse output plus ±0.1% of rate ±0.01 mA

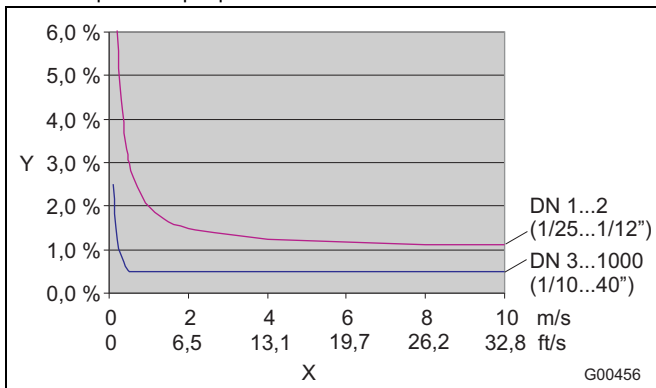

Fig. 1

- Y Accuracy ± of rate
- X Flow velocity v

2.2 Grounding

The grounding of the flowmeter sensor is essential for both safety reasons, and to ensure trouble-free operation of the electromagnetic flowmeter. The ground screws on the flowmeter sensor are to be brought to ground potential. For technical reasons, this potential should be identical to the potential of the metering fluid, if possible.

For plastic or insulated lined pipelines, the fluid is grounded by installing ground plates. When there are stray potentials present in the pipeline, we recommend installing a ground plate on both ends of the flowmeter sensor.

To comply with the EMC and Low Voltage Directives, the connection box/ transmitter must be grounded in addition to the meter tube of the flowmeter sensor.

2.3 Installation Requirements

The device measures the flowrate in both directions. Forward flow is the factory setting, as shown in Fig. 2.

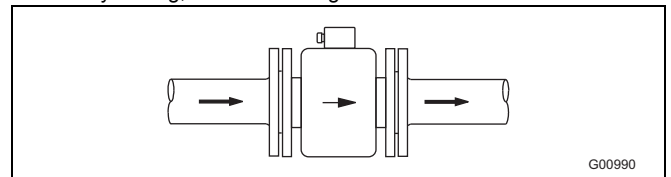

Fig. 2

The following items must be observed:

2.3.1 Electrode axis

Electrode axis (1) as level as possible or rotated max. 45°.

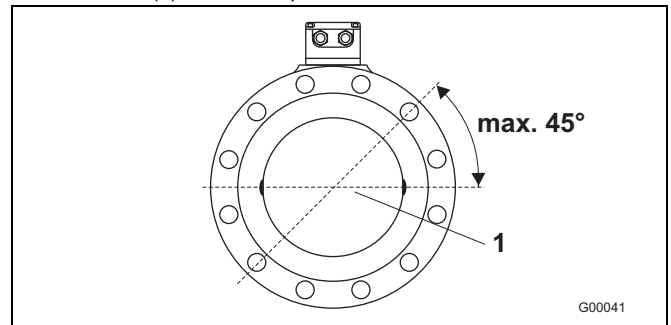

Fig. 3

2.3.2 In- and outlet pipe sections

The metering principle is independent of the flow profile as long as standing eddies do not extend into the metering section, such as may occur after double elbows (1), in the event of tangential inflow, or where half-open gate valves are located upstream of the flowmeter sensor.

In such cases, measures must be put in place to normalize the flow profile.

- Do not install fittings, manifolds, valves, etc., directly in front of the flowmeter sensor (1).
- Butterfly valves must be installed so that the valve plate does not extend into the flowmeter sensor.
- Valves or other turn-off components should be installed in the outlet pipe section (2).

Experience has shown that, in most installations, straight inlet sections 3 x DN long and straight outlet sections 2 x DN long are sufficient (DN = nominal diameter of the sensor Fig. 4).

For test stands, the reference conditions of 10 x DN straight inlet and 5 x DN straight outlet must be provided, in accordance with EN 29104 / ISO 9104.

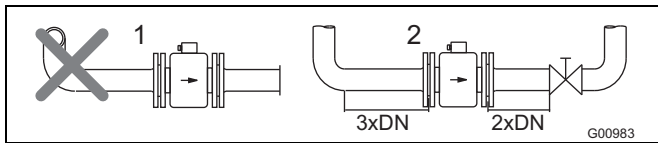

Fig. 4

2.3.3 Vertical connections

- Vertical installation for measuring abrasive fluids, preferably with flow in upward direction.

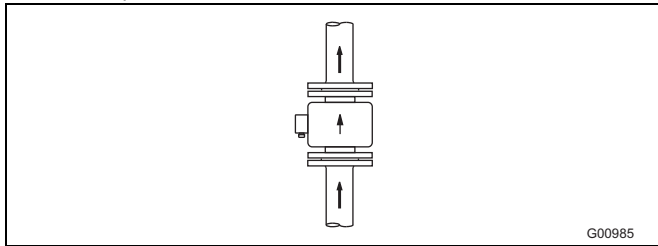

Fig. 5

2.3.4 Horizontal connections

- The measuring tube must always be full.
- Provide for a slight incline of the connection for degassing.

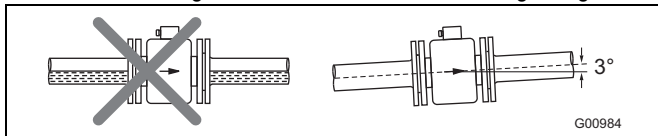

Fig. 6

2.3.5 Free inlet or outlet

- For a free outflow, do not install flowmeter at the highest point in the pipeline, since measuring tube may empty, creating bubbles (1).
- For free inflow/outflow, provide an invert, to ensure that the pipeline is always full (2).

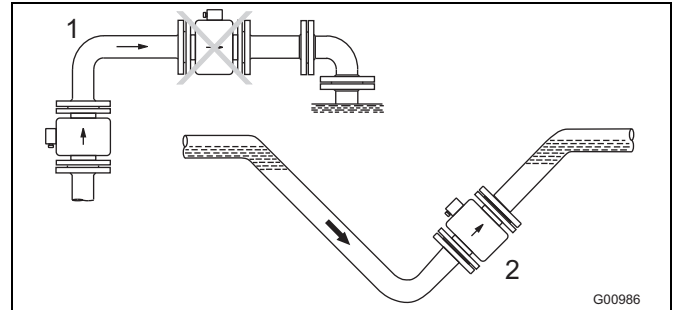

Fig. 7

2.3.6 Strongly contaminated fluids

- For strongly contaminated fluids, a bypass connection according to the figure is recommended so that operation of the system can continue to run without interruption during the mechanical cleaning.

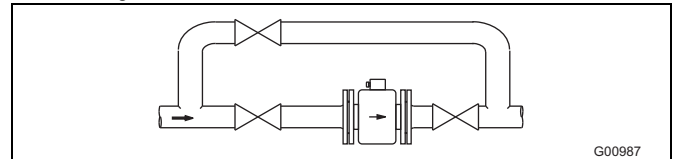

Fig. 8

2.3.7 Installation in the vicinity of pumps

- For flowmeter sensors that are installed near pumps or other vibration-causing fixtures, the use of mechanical vibration control components is mandatory.

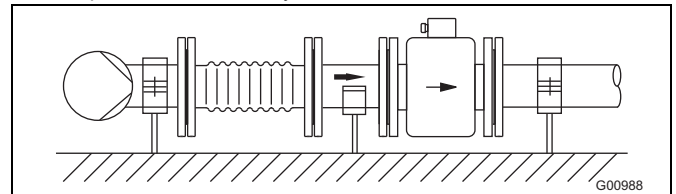

Fig. 9

2.3.8 Installing the high temperature design

The high temperature design allows for complete thermal insulation of the sensor. The pipeline and sensor must be insulated after installing the unit according to the following illustration.

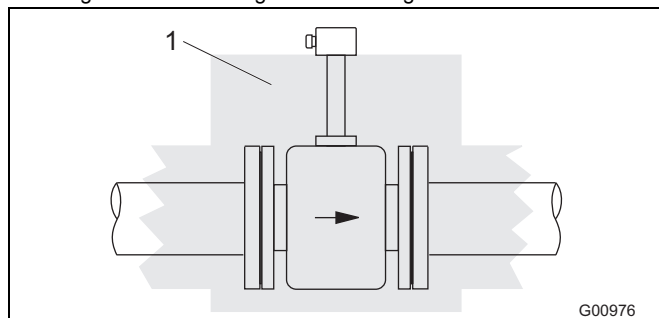

Fig. 10
1 Insulation

2.3.9 Installation in pipelines with larger nominal diameter

Determine the resulting pressure loss when using reduction pieces (1):

1. Calculate the diameter ratio d/D .
2. Determine the flow velocity based on the flow range nomograph (Fig. 12).
3. Read the pressure drop on the Y-axis in Fig. 12.

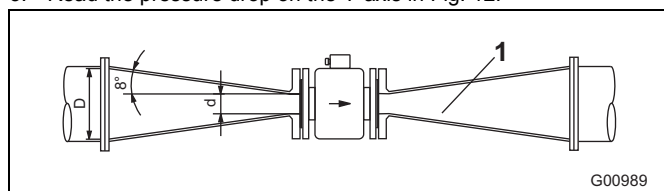

Fig. 11
d Inside diameter of the flowmeter
v Flow velocity [m/s]
 Δp Pressure loss [mbar]
D Inside diameter of the pipeline

Nomograph for pressure drop determinations

For adaptor with $\alpha/2 = 8^\circ$

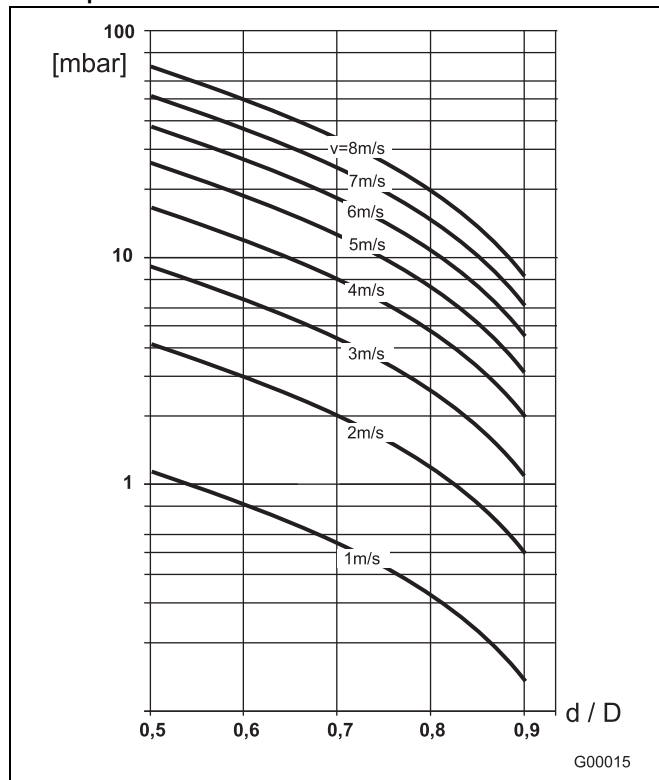

Fig. 12

2.4 Flowmeter Sizes, Pressure Ratings, Flow Range

Meter size DN		Standard pressure rating PN	Min. flow velocity measuring range 0 ... 0.5 m/s					Max. flow velocity measuring range 0 ... 10 m/s				
1	1/25	10	0 ...	0.03	l/min	0.00792	US gal/min	0 ...	0.6	l/min	0.158	US gal/min
1.5	1/16	10	0 ...	0.06	l/min	0.0159	US gal/min	0 ...	1.2	l/min	0.317	US gal/min
2	1/12	10	0 ...	0.1	l/min	0.0265	US gal/min	0 ...	2	l/min	0.529	US gal/min
3	1/10	40	0 ...	0.2	l/min	0.0529	US gal/min	0 ...	4	l/min	1.06	US gal/min
4	5/32	40	0 ...	0.4	l/min	0.1	US gal/min	0 ...	8	l/min	2.1	US gal/min
6	1/4	40	0 ...	1	l/min	0.3	US gal/min	0 ...	20	l/min	5.3	US gal/min
8	5/16	40	0 ...	1.5	l/min	0.4	US gal/min	0 ...	30	l/min	7.9	US gal/min
10	3/8	40	0 ...	2.25	l/min	0.6	US gal/min	0 ...	45	l/min	12	US gal/min
15	1/2	40	0 ...	5.0	l/min	1.3	US gal/min	0 ...	100	l/min	36	US gal/min
20	3/4	40	0 ...	7.5	l/min	2.0	US gal/min	0 ...	150	l/min	40	US gal/min
25	1	40	0 ...	10	l/min	2.6	US gal/min	0 ...	200	l/min	53	US gal/min
32	1 1/4	40	0 ...	20	l/min	5.3	US gal/min	0 ...	400	l/min	106	US gal/min
40	1 1/2	40	0 ...	30	l/min	7.9	US gal/min	0 ...	600	l/min	159	US gal/min
50	2	40	0 ...	3	m ³ /h	13	US gal/min	0 ...	60	m ³ /h	264	US gal/min
65	2 1/2	40	0 ...	6	m ³ /h	26	US gal/min	0 ...	120	m ³ /h	528	US gal/min
80	3	40	0 ...	9	m ³ /h	40	US gal/min	0 ...	180	m ³ /h	793	US gal/min
100	4	16	0 ...	12	m ³ /h	53	US gal/min	0 ...	240	m ³ /h	1057	US gal/min
125	5	16	0 ...	21	m ³ /h	92	US gal/min	0 ...	420	m ³ /h	1849	US gal/min
150	6	16	0 ...	30	m ³ /h	132	US gal/min	0 ...	600	m ³ /h	2642	US gal/min
200	8	10/16	0 ...	54	m ³ /h	238	US gal/min	0 ...	1080	m ³ /h	4755	US gal/min
250	10	10/16	0 ...	90	m ³ /h	396	US gal/min	0 ...	1800	m ³ /h	7925	US gal/min
300	12	10/16	0 ...	120	m ³ /h	528	US gal/min	0 ...	2400	m ³ /h	10567	US gal/min
350	14	10/16	0 ...	165	m ³ /h	726	US gal/min	0 ...	3300	m ³ /h	14529	US gal/min
400	16	10/16	0 ...	225	m ³ /h	991	US gal/min	0 ...	4500	m ³ /h	19813	US gal/min
450	18	10/16	0 ...	300	m ³ /h	1321	US gal/min	0 ...	6000	m ³ /h	26417	US gal/min
500	20	10	0 ...	330	m ³ /h	1453	US gal/min	0 ...	6600	m ³ /h	29059	US gal/min
600	24	10	0 ...	480	m ³ /h	2113	US gal/min	0 ...	9600	m ³ /h	30380	US gal/min
700	28	10	0 ...	660	m ³ /h	2906	US gal/min	0 ...	13200	m ³ /h	58118	US gal/min
800	32	10	0 ...	900	m ³ /h	3963	US gal/min	0 ...	18000	m ³ /h	79252	US gal/min
900	36	10	0 ...	1200	m ³ /h	5283	US gal/min	0 ...	24000	m ³ /h	105669	US gal/min
1000	40	10	0 ...	1350	m ³ /h	5944	US gal/min	0 ...	27000	m ³ /h	118877	US gal/min

Flange design and pressure rating

Nominal diameter	Flange ¹⁾	Material	PN	PED		
1 ... 2 (1/25 ... 1/12")	1/8" sanitary	Stainless steel 1.4571 (316 Ti) or POM, brass, PVC	10 bar	SEP Sec. 3 Para. 3		
	DIN				Stainless steel or steel	40, 63, 100 bar
						CL150, CL300, CL600 ³⁾
ASME	10 bar					
JIS						
3 ... 25 (1/10 ... 1")	DIN	Stainless steel or steel	40 bar			
	ASME				CL150, CL300	
	JIS				10 bar	
32 (1 1/4")	DIN	Stainless steel or steel	40 bar			
	ASME				CL150, CL300	
	JIS				10 bar	
40 (1 1/2")	DIN	Stainless steel or steel	40, 63, 100 bar			
	ASME			CL150, CL300, CL600		
	JIS			10 bar		
50 (2")	DIN	Stainless steel or steel	40, 63, 100 bar			
	ASME			CL150, CL300, CL600		
	JIS			10 bar		
65 (2 1/2")	DIN	Stainless steel or steel	16, 40, 63, 100 bar			
	ASME			CL150, CL300, CL600		
	JIS			10 bar		
80 (3")	DIN	Stainless steel or steel	40, 63, 100 bar			
	ASME			CL150, CL300, CL600		
	JIS			10 bar		
100 (4")	DIN	Stainless steel or steel	16, 40, 63, 100 bar			
	ASME			CL150, CL300, CL600		
	JIS			10 bar		
125 (5")	DIN	Stainless steel or steel	16, 40, 63, 100 bar			
	ASME			CL150, CL300		
	JIS			10 bar		
150 (6")	DIN	Stainless steel or steel	16, 40, 63, 100 bar			
	ASME			CL150, CL300, CL600		
	JIS			10 bar		
	ASME			CL150		

Conformity assessment in accordance with category III, module B1 + D, fluid group 1

Nominal diameter	Flange ¹⁾	Material	PN	PED	
200 (8")	DIN	Stainless steel or steel	10, 16, 25, 40, 63, 100 bar	Conformity assessment in accordance with category III, module B1 + D, fluid group 1	
	ASME				CL150, CL300, CL600
	JIS				10 bar
250 (10")	DIN	Stainless steel or steel	10, 16, 25, 40 bar		
	ASME				CL150, CL300
	JIS				10 bar
300 (12")	DIN	Stainless steel or steel	10, 16, 25, 40 bar		
	ASME				CL150, CL300
	JIS				10 bar
350 ... 600 (14 ... 24")	DIN	Stainless steel or steel	10, 16, 25 bar		
	ASME				CL150, CL300
	JIS				10 bar
700 ... 1000 (28 ... 40")	DIN	Stainless steel or steel	10, 16, 25 bar		
	ASME			CL150	

1) Connecting dimensions for flange acc. to DIN2501 / EN1092-1 or ASME or JIS.
 2) PN63, PN100 only for nominal diameters DN15 and DN25.
 3) CL600 only for nominal diameters DN15 and DN25.

Other meter sizes, pressure stages and temperature classes are available upon request.

2.5 Flowrate nomograph

The volume flowrate is a function of the flow velocity and the diameter of the flowmeter. The flowrate nomograph indicates the flowrate range for a specific flowmeter nominal diameter and which flowmeter nominal diameters are suitable for a specific flowrate.

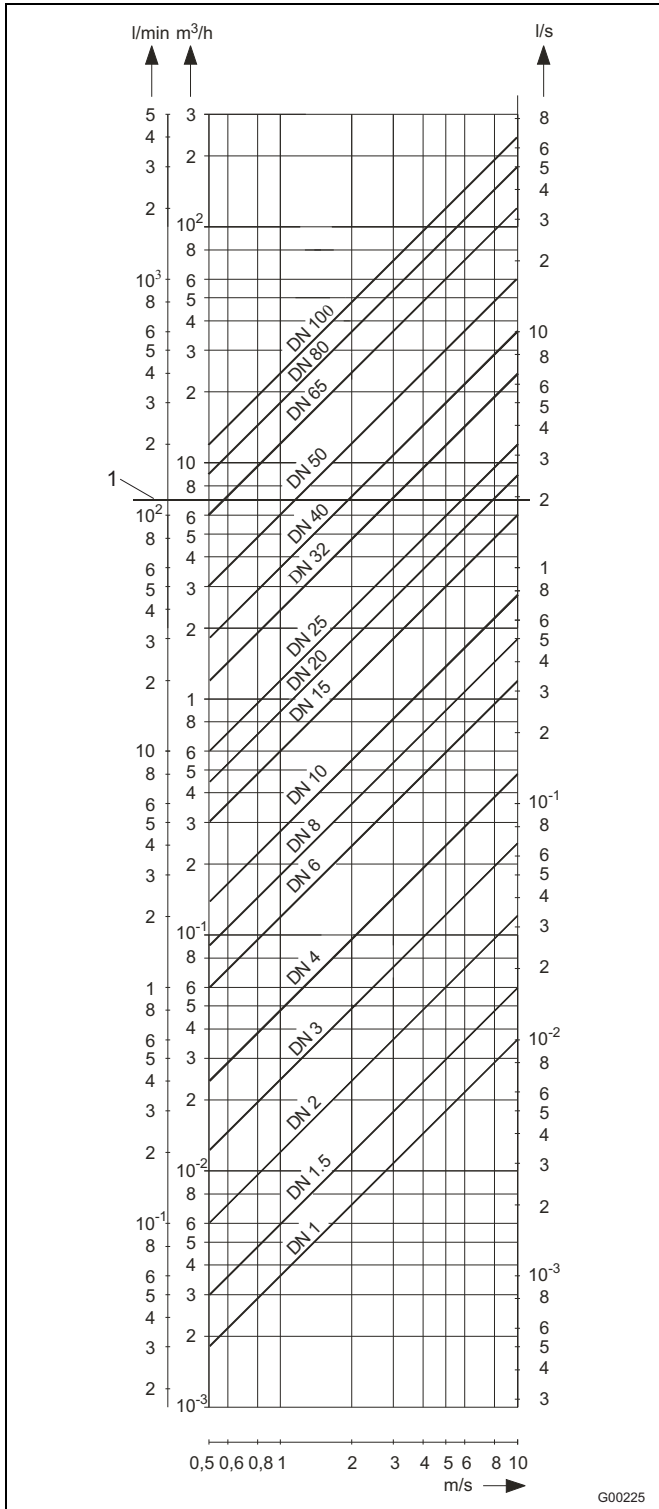

Fig. 13: Flowrate nomograph DN 1 ... DN 100 (1/25 ... 4")

1 Example

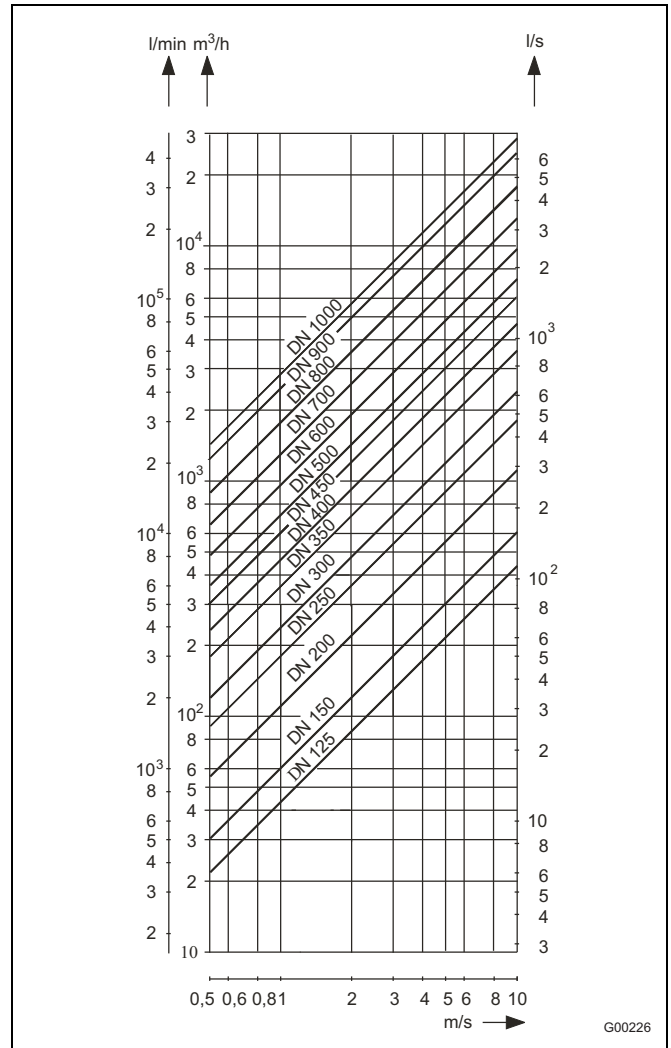

Fig. 14: Flowrate nomograph DN 125 ... DN 1000 (5 ... 40")

Example:

Flowrate = 7 m³/h (max. value = range end value). Sensor nominal diameters DN 20 ... DN 65 (3/4 ... 2 1/2") are suitable for a flow velocity of 0.5 ... 10 m/s.

3 Model SE41F

3.1 Specifications

Temperature graph

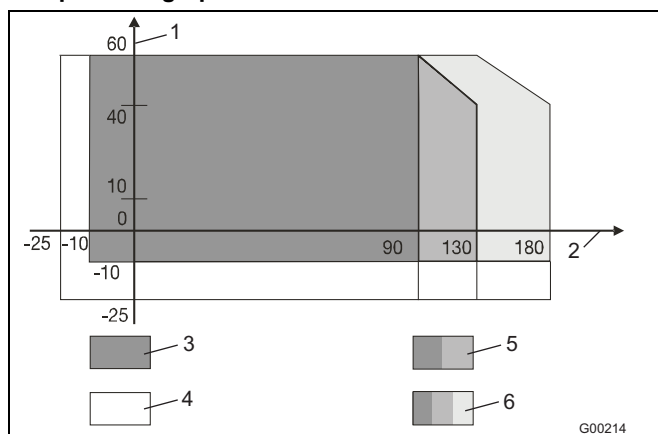

Fig. 15: Fluid temperature as function of ambient temperature

- 1 Ambient temperature °C
- 2 Fluid temperature °C
- 3 Standard flange (steel): Hard/soft rubber max. 90 / 60 °C (194 ... 140 °F)
- 4 Stainless steel flange
- 5 Standard flange (steel): PTFE / PFA / ETFE max. 130 °C (266 °F)
- 6 High temperature: Thick PTFE / PFA max. 180 °C (356 °F)

Max. allowable cleaning temperature PTFE-, PFA-design

CIP cleaning	Liner Flowmeter sensor	T _{max}	t _{max} Min	T _{amb.}
Steam cleaning	PTFE, PFA	150 °C (302 °F)	60	25 °C (77 °F)
Wet cleaning	PTFE, PFA	140 °C (284 °F)	60	25 °C (77 °F)

If the ambient temperature is > 25 °C, then the difference must be subtracted from the max. cleaning temperature.

$$T_{max} - \Delta \text{ °C} \cdot \Delta \text{ °C} = (T_{amb.} - 25 \text{ °C})$$

Weight

See "Dimensions"

Min. permissible pressure as a function of fluid temperature

Lining	Nominal diameter DN	P _{Operation} at mbar abs	T _{Operating}
Hard rubber	15 ... 1000 (1/2 ... 40")	0	< 90 °C (194 °F)
		0	< 60 °C (140 °F)
PTFE	10 ... 600 (3/8 ... 24")	270	< 20 °C (68 °F)
		400	< 100 °C (212 °F)
		500	< 130 °C (266 °F)
Thick PTFE high-temperature design	25 ... 80 (1 ... 3") 100...250 (4...10") 300 (12")	0	< 180 °C (356 °F)
		67	< 180 °C (356 °F)
		27	< 180 °C (356 °F)
PFA	3 ... 200 (1/10 ... 8")	0	< 130 °C (266 °F)
		0	< 180 °C (356 °F)
ETFE	25...1000 (1...40")	100	< 130 °C (266 °F)
Ceramic carbide	25 ... 1000 (1 ... 40")	0	< 80 °C (176 °F)

Flowmeter sensor material

Parts	Standard	Others
Lining	PTFE, PFA, hard rubber, soft rubber, ETFE	Ceramic carbide
Signal and ground electrode for - Hard rubber - Soft rubber	Stainless steel 1.4571 (316 Ti)	Hastelloy B-3 (2.4600), Hastelloy C-4 (2.4610), Titanium, tantalum, Platinum-iridium, Stainless steel 1.4539 (904 L)
- PTFE, PFA, ETFE	Hastelloy C-4 (2.4610)	Stainless steel 1.4571 (316 Ti) Hastelloy B-3 (2.4600), Titanium, tantalum, Platinum-iridium, Stainless steel 1.4539 (904 L)
Grounding plate	Stainless steel 1.4571 (316 Ti)	On request
Protection plate	Stainless steel 1.4571 (316 Ti)	On request

Process connection material

Parts	Standard	Others
Flange		
DN 3 ... DN 15 (1/10 ... 1/2")	Stainless steel ¹⁾	Stainless steel ¹⁾
DN 20 ... DN 300 (3/4 ... 12")	Galvanized steel ²⁾	
DN 350 ... DN 1000 (14 ... 40")	Painted steel ²⁾	
Housing		
DN 3 ... 300 (1/10 ... 12")	Dual-shell casing, cast aluminum, painted, paint coat, ≥ 80 µm thick, RAL 9002	-
DN 350 ... DN 1000 (14 ... 40")	Welded steel design, painted, paint coat, ≥ 80 µm thick, RAL 9002	-
Terminal box	Al alloy, painted, ≥ 80 µm dick, frame: dark gray, RAL 7012 Cover: light gray, RAL 9002	-
Meter tube	Stainless steel 1.4301 (304)	-
cable gland used	Polyamide	-

The process connections are made of one of the materials listed below:

- 1) 1.4301 (304), 1.4307, 1.4404 (316L), 1.4435 (316L), 1.4541 (321), 1.4571 (316Ti), ASTM A182 F304, ASTM A182 F304L, ASTM A182 F316L, ASTM A182 F321, ASTM A182 F316Ti, ASTM A182 F316, 0Cr18Ni9, 0Cr18Ni10, 0Cr17Ni13Mo2, 0Cr27Ni12Mo3, 1Cr18Ni9Ti, 0Cr18Ni12Mo2Ti
- 2) 1.0038, 1.0460, 1.0570, 1.0432, ASTM A105, Q235A, 20#, 16Mn

Storage temperature

-20 ... 70 °C (-4 ... 158 °F)

Degree of protection acc. to EN 60529

IP 65 / IP 67
IP 68 (option)

Pipeline vibration according to EN 60068-2-6

- Transmitter
- In the range of 10...55 Hz, max. deflection 0.15 mm
- Flowmeter sensor
- In the range of 10...55 Hz, max. deflection 0.15 mm
 - In the range of 10...55 Hz, max. acceleration 2 g

Designs

The flanged flowmeters comply with the installation lengths specified in VDI / VDE 2641, ISO 13359 or according to DVGW (process sheet W420, design WP; ISO 4064 short).

Material load

Limits for allowable fluid temperature (TS) and allowable pressure (PS) are a function of the liner and flange material used (see the factory tag and name plate of the unit).

Temperature limits

Lining	Flange material	Min. temperature	Max. temperature	
			Standard	High temperature
Hard rubber	Steel	-10 °C (14 °F)	90 °C (194 °F)	-
	Stainless steel	-15 °C (5 °F)	90 °C (194 °F)	-
Soft rubber	Steel	-10 °C (14 °F)	60 °C (140 °F)	-
	Stainless steel	-15 °C (5 °F)	60 °C (140 °F)	-
PTFE / ETFE	Steel	-10 °C (14 °F)	130 °C (266 °F)	-
	Stainless steel	-25 °C (-13 °F)	130 °C (266 °F)	-
Thick PTFE / PFA	Steel	-10 °C (14 °F)	130 °C (266 °F)	180 °C (356 °F)
	Stainless steel	-25 °C (-13 °F)	130 °C (266 °F)	180 °C (356 °F)
Ceramic carbide	Steel	-10 °C (14 °F)	80 °C (176 °F)	-
	Stainless steel	-20 °C (-4 °F)	80 °C (176 °F)	-

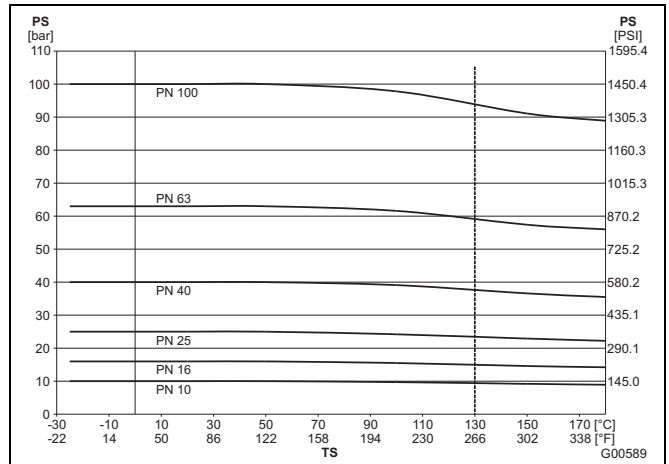

Fig. 16: Stainless steel DIN flange up to DN 600 (24")

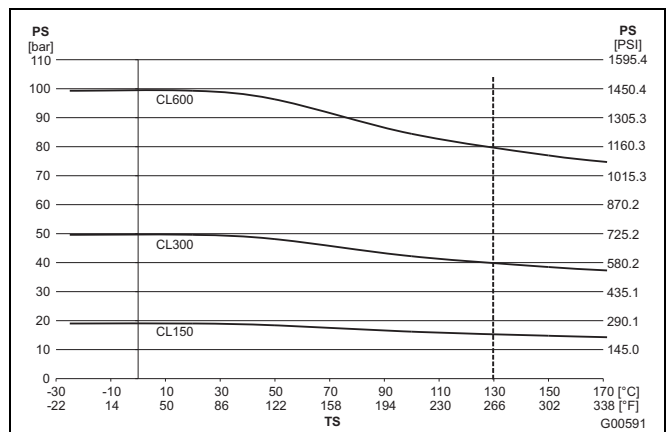

Fig. 17: Stainless steel ASME flange up to DN 400 (16") (CL150/300); up to DN 1000 (40") (CL150); up to DN 200 (8") (CL 600)

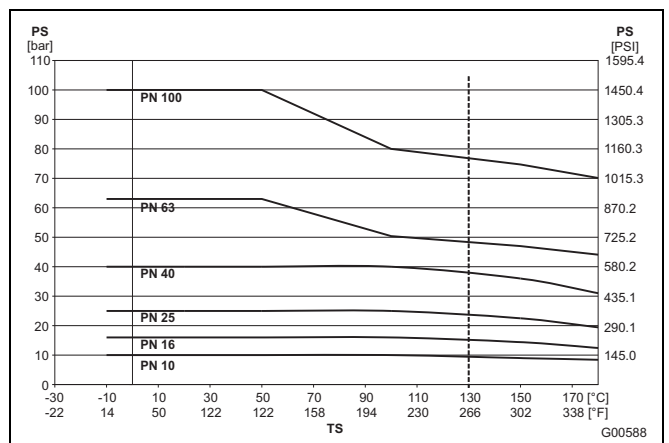

Fig. 18: DIN flange SS to DN 600 (24")

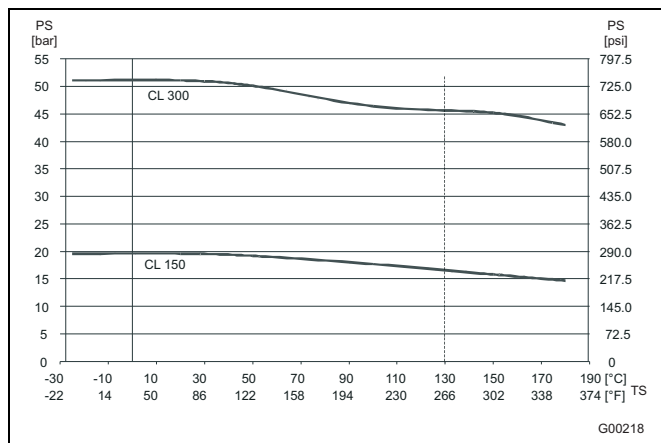

Fig. 19: Steel ASME flange up to DN 400 (16") (CL150/300); up to DN 1000 (40") (CL150)

JIS 10K-B2210 Flange

Nominal size DN	Material	PN	TS	PS [bar]
32 ... 400 (1¼ ... 16")	Stainless steel	10	-25 ... +180 °C (-13 ... +356 °F)	10
32 ... 400 (1¼ ... 16")	Steel	10	-10 ... +180 °C (14 ... 266 °F)	10

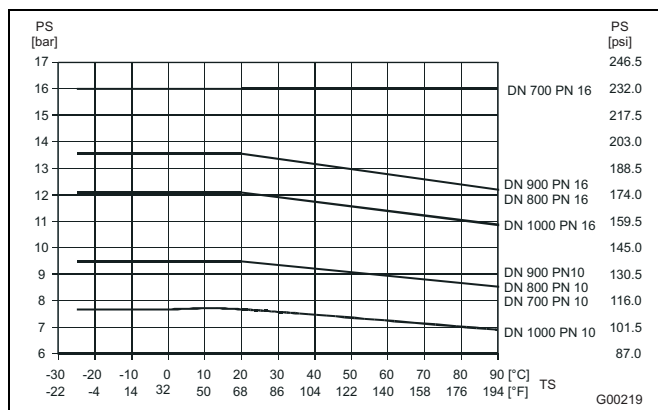

Fig. 20: Stainless steel DIN flange, DN 700 ... DN 1000 (28 ... 40")

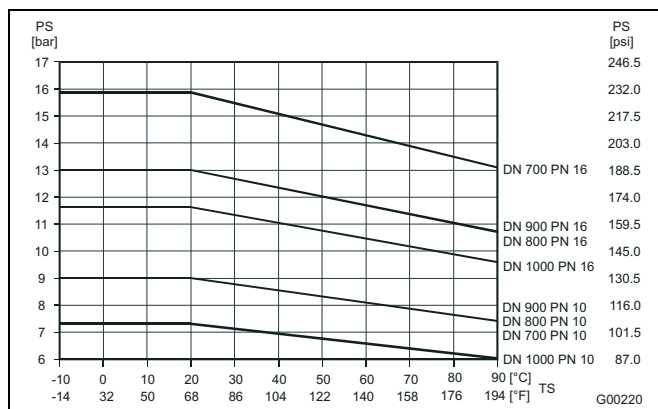

Fig. 21: DIN flange steel, DN 700 ... DN 1000 (28 ... 40")

3.2 Dimensions

3.2.1 Model SE41F

Flange DN 3 ... 125 (1/10 ... 5")

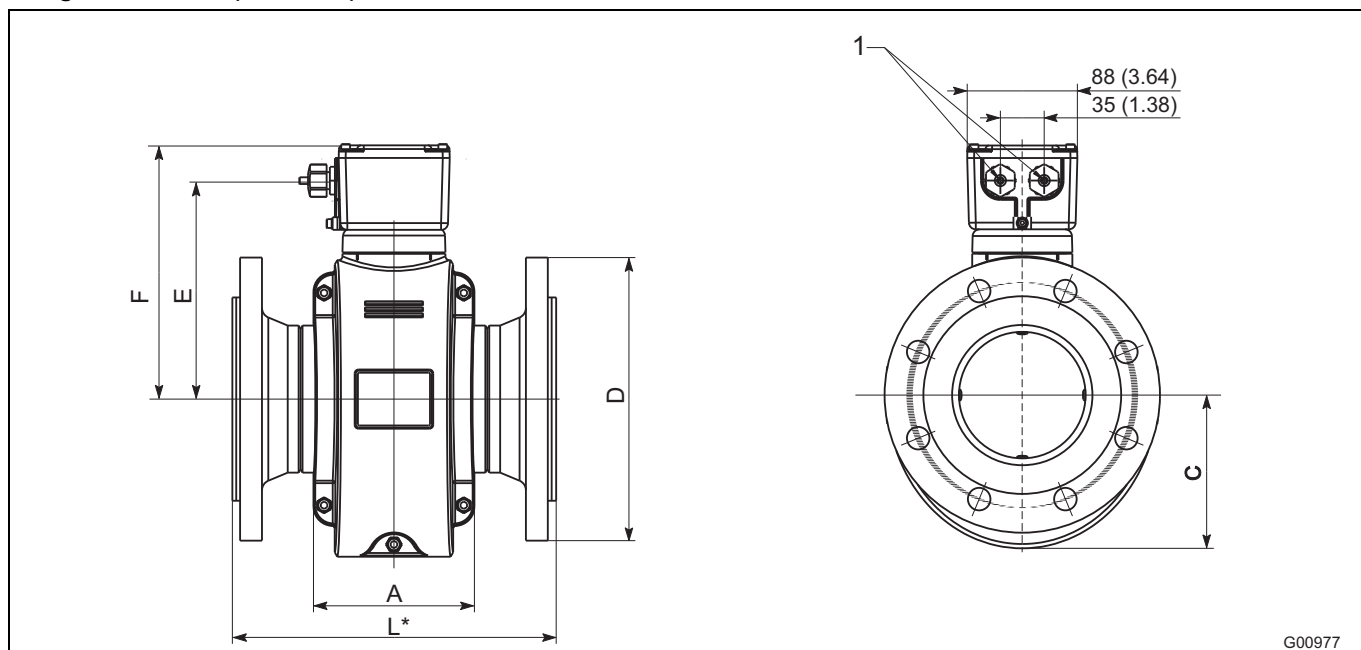

Fig. 22: Dimensions in mm (inch)

1 Cable gland M20 x 1.5 or NPT

Flange in acc. with DIN/EN 1092-1

Dimensions [mm]								Approx. weight [kg]
DN	PN 1)	D	L 2) 3)	F 4)	C	E 4)	A	
3 ... 8 5)	10 ... 40	90	200	154	82	126	113	5
10	10 ... 40	90	200	154	82	126	113	5
15	10 ... 40	95	200	154	82	126	113	6
20	10 ... 40	105	200	154	82	126	113	6
25	10 ... 40	115	200	154	82	126	113	7
32	10 ... 40	140	200	161	92	133	113	8
40	10 ... 40	150	200	161	92	133	113	9
50	10 ... 40	165	200	167	97	139	115	10
65	10 ... 40	185	200	178	108	150	104	13
80	10 ... 40	200	200	178	108	150	104	15
100	10 ... 16	220	250	200	122	172	125	17
	25 ... 40	235	250	200	122	172	125	21
125	10 ... 16	250	250	210	130	182	125	20
	25 ... 40	270	250	210	130	182	125	27

Tolerance L: +0 / -3 mm

Dimensions [inch]								Approx. weight [lb]
DN (inch)	PN 1)	D	L 2) 3)	F 4)	C	E 4)	A	
3 ... 8 5) (1/8 ... 5/16)	10 ... 40	3.54	7.87	6.06	3.23	4.96	4.45	11
10 (3/8)	10 ... 40	3.54	7.87	6.06	3.23	4.96	4.45	11
15 (1/2)	10 ... 40	3.74	7.87	6.06	3.23	4.96	4.45	13.23
20 (3/4)	10 ... 40	4.13	7.87	6.06	3.23	4.96	4.45	13.23
25 (1)	10 ... 40	4.53	7.87	6.06	3.23	4.96	4.45	15.43
32 (1 1/4)	10 ... 40	5.51	7.87	6.34	3.62	5.24	4.45	17.64
40 (1 1/2)	10 ... 40	5.91	7.87	6.34	3.62	5.24	4.45	19.84
50 (2)	10 ... 40	6.50	7.87	6.57	3.82	5.47	4.53	22.05
65 (2 1/2)	10 ... 40	7.28	7.87	7.01	4.25	5.91	4.09	28.66
80 (3)	10 ... 40	7.87	7.87	7.01	4.25	5.91	4.09	33.07
100 (4)	10 ... 16	8.66	9.84	7.87	4.80	6.77	4.92	37.48
	25 ... 40	9.25	9.84	7.87	4.80	6.77	4.92	46.30
125 (5)	10 ... 16	9.84	9.84	8.27	5.12	7.17	4.92	44.09
	25 ... 40	10.63	9.84	8.27	5.12	7.17	4.92	59.52

Tolerance L: +0 / -0.018 inch

Flange in acc. with ASME B16.5

Dimensions [mm]										Approx. weight [kg]
		CL150		CL300						
		ISO 133359		ISO 133359						
DN	Inch	D	L ^{2) 3)}	D	L ^{2) 3)}	F ⁴⁾	C	E ⁴⁾	A	
3 ... 8	1/8 ... 5/16 ⁶⁾	89	200	96	200	154	82	126	113	5
10	3/8 ⁶⁾	89	200	96	200	154	82	126	113	5
15	1/2	89	200	96	200	154	82	126	113	6
20	3/4	98	200	118	200	154	82	126	113	6
25	1	108	200	124	200	154	82	126	113	7
32	1 1/4	118	200	134	200	161	92	133	113	9
40	1 1/2	127	200	156	200	161	92	133	113	9
50	2	153	200	165	200	167	97	139	115	11
65	2 1/2	178	200	191	200	178	108	150	104	13
80	3	191	200	210	200	178	108	150	104	17
100	4	229	250	254	250	200	122	172	125	19 / 28
125	5	254	250	280	250	210	130	182	125	20 / 33

Tolerance L: +0 / -3 mm

Dimensions [inch]										Approx. weight [lb]
		CL150		CL300						
		ISO 133359		ISO 133359						
DN	Inch	D	L ^{2) 3)}	D	L ^{2) 3)}	F ⁴⁾	C	E ⁴⁾	A	
3 ... 8	1/8 ... 5/16 ⁶⁾	3.5	7.87	3.78	7.87	6.06	3.23	4.96	4.45	11
10	3/8 ⁶⁾	3.5	7.87	3.78	7.87	6.06	3.23	4.96	4.45	11
15	1/2	3.5	7.87	3.78	7.87	6.06	3.23	4.96	4.45	13.2
20	3/4	3.86	7.87	4.65	7.87	6.06	3.23	4.96	4.45	13.2
25	1	4.25	7.87	4.88	7.87	6.06	3.23	4.96	4.45	15.4
32	1 1/4	4.65	7.87	5.28	7.87	6.34	3.62	5.24	4.45	19.8
40	1 1/2	5	7.87	6.14	7.87	6.34	3.62	5.24	4.45	19.8
50	2	6.02	7.87	6.5	7.87	6.57	3.82	5.47	4.53	24.3
65	2 1/2	7.01	7.87	7.52	7.87	7.01	4.25	5.91	4.09	28.66
80	3	7.52	7.87	8.27	7.87	7.01	4.25	5.91	4.09	37.48
100	4	9.02	9.84	10	9.84	7.87	4.80	6.77	4.92	41.89 / 61.73
125	5	10	9.84	11.02	9.84	8.27	5.12	7.17	4.92	44.09 / 72.75

Tolerance L: +0 / -0.118 inch

1) Other pressure ratings available on request.

2) If a grounding plate is installed (attached to one side of the flange), this increases dimension L as follows: DN 3 ... 100 by 3 mm (0.118 inch); DN 125 by 5 mm (0.197 inch).

3) If protection plates are installed (attached to both sides of the flange), this increases dimension L as follows: DN 3 ... 100 by 6 mm (0.236 inch); DN 125 by 10 mm (0.394 inch).

4) Depending on the device design, the dimensions change according to the following table.

Device design	Dimension E, F
Standard temperature design	0
High temperature version	+127 mm (+5 inch)

5) Connection flange DN 10

6) Connection flange 1/2"

7) Connecting dimensions in acc. with EN 1092-1. For DN 65, PN 16 in acc. with EN 1092-1, please order PN 40.

3.2.2 Flange DN 150 ... 300 (6 ... 12")

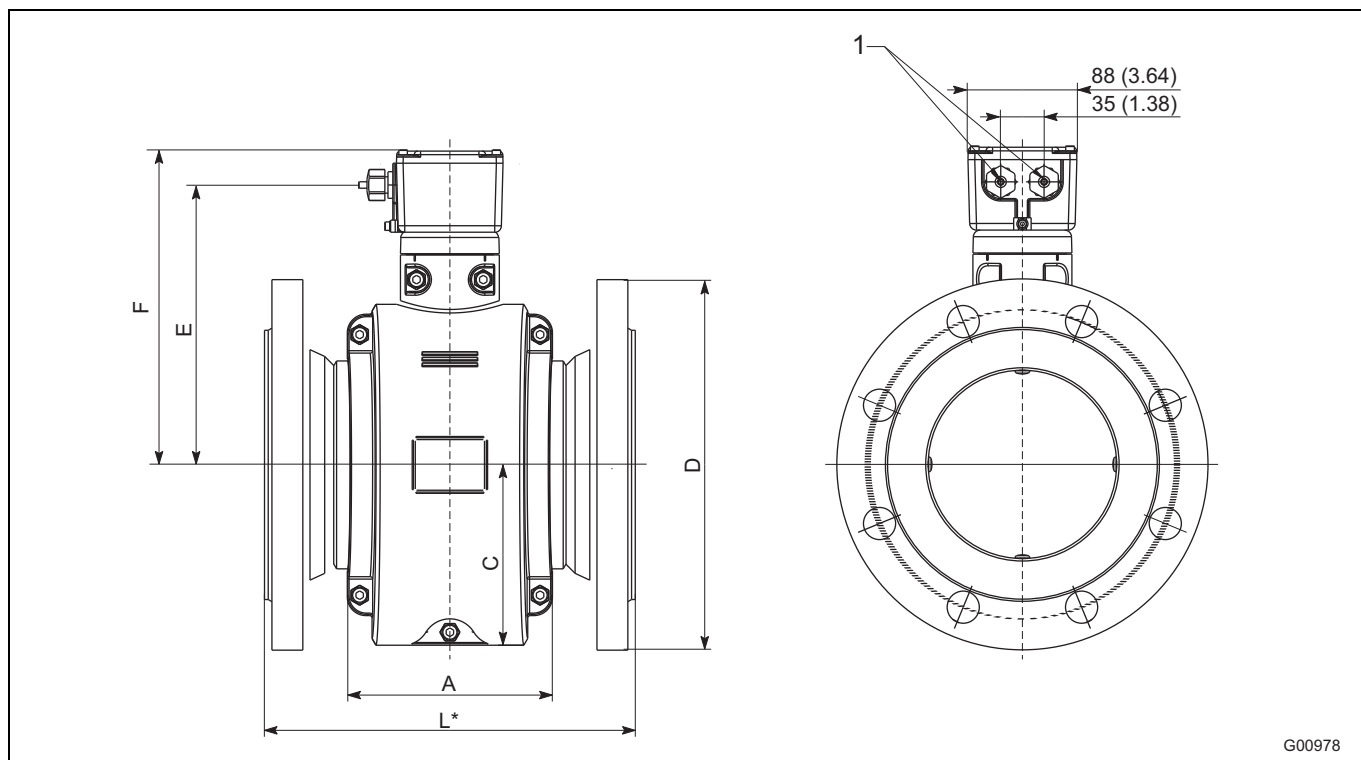

Fig. 23: Dimensions in mm (inch)

1 Cable gland M20 x 1.5 or NPT

Flange in acc. with DIN/EN 1092-1

Dimensions [mm]								Approx. weight [kg]
DN	PN 1)	D	L ^{2) 3)}	F 4)	C	E 4)	A	
150	10 ... 16	285	300	257	146	229	166	31
	25 ... 40	300	300	257	146	229	166	37
200	10	340	350	283	170	255	200	39
	16	340	350	283	170	255	200	41
250	10	395	450	312	198	284	235	59
	16	405	450	312	198	284	235	63
300	10	445	500	335	228	307	272	72
	16	460	500	335	228	307	272	78

Tolerance L: DN 150 ... 200 +0 / -3 mm, DN 250 ... 300+0 / -5 mm

Dimensions [inch]								Approx. weight [lb]
DN	PN 1)	D	L ^{2) 3)}	F 4)	C	E 4)	A	
150 (6)	10 ... 16	11.22	11.81	10.12	5.75	9.02	6.54	68.34
	25 ... 40	11.81	11.81	10.12	5.75	9.02	6.54	81.57
200 (8)	10	13.39	13.78	11.14	6.69	10.04	7.87	85.98
	16	13.39	13.78	11.14	6.69	10.04	7.87	90.39
250 (10)	10	15.55	17.72	12.28	7.80	11.18	9.25	130.07
	16	15.94	17.72	12.28	7.80	11.18	9.25	138.89
300 (12)	10	17.52	19.68	13.19	8.98	12.09	10.71	158.73
	16	18.11	19.68	13.19	8.98	12.09	10.71	171.96

Tolerance L: DN 150 ... 200 +0 / -0.118 inch, DN 250 ... 300 +0 / -0.197 inch

Flange in acc. with ASME B16.5

Dimensions [mm]										Approx. weight [kg]
		CL150		CL300						
		ISO 13359		ISO 13359						
DN	Inch	D	L ^{2) 3)}	D	L ^{2) 3)}	F ⁴⁾	C	E ⁴⁾	A	
150	6	280	300	318	300	257	146	229	166	31 / 45
200	8	343	350	381	350	283	170	255	200	48 / 70
250	10	407	450	445	450	312	198	284	235	68 / 103
300	12	483	500	521	500	335	228	307	272	103 / 148

Tolerance L: DN 150 ... 200 +0 / -3 mm, DN 250 ... 300+0 / -5 mm

Dimensions [inch]										Approx. weight [lb]
		CL150		CL300						
		ISO 13359		ISO 13359						
DN	Inch	D	L ^{2) 3)}	D	L ^{2) 3)}	F ⁴⁾	C	E ⁴⁾	A	
150	6	11.02	11.81	12.52	11.81	10.12	5.75	9.02	6.54	68.34 / 99.21
200	8	13.5	13.78	15	13.78	11.14	6.69	10.04	7.87	105.82 / 154.32
250	10	16.02	17.72	17.52	17.72	12.28	7.80	11.18	9.25	149.91 / 227.08
300	12	19.02	19.69	20.51	19.69	13.19	8.98	12.09	10.71	227.08 / 326.28

Tolerance L: DN 150 ... 200 +0 / -0.118 inch, DN 250 ... 300 +0 / -0.197 inch

1) Other pressure ratings available on request.

2) If a grounding plate is installed (attached to one side of the flange), this increases dimension L by 5 mm (0.197 inch).

3) If protection plates are installed (attached to both sides of the flange), this increases dimension L by 10 mm (0.394 inch).

4) Depending on the device design, the dimensions change according to the following table.

Device design	Dimension E, F
Standard temperature design	0
High temperature version	+127 mm (+5 inch)

3.2.3 Flange DN 350 ... 1000 (16 ... 40")

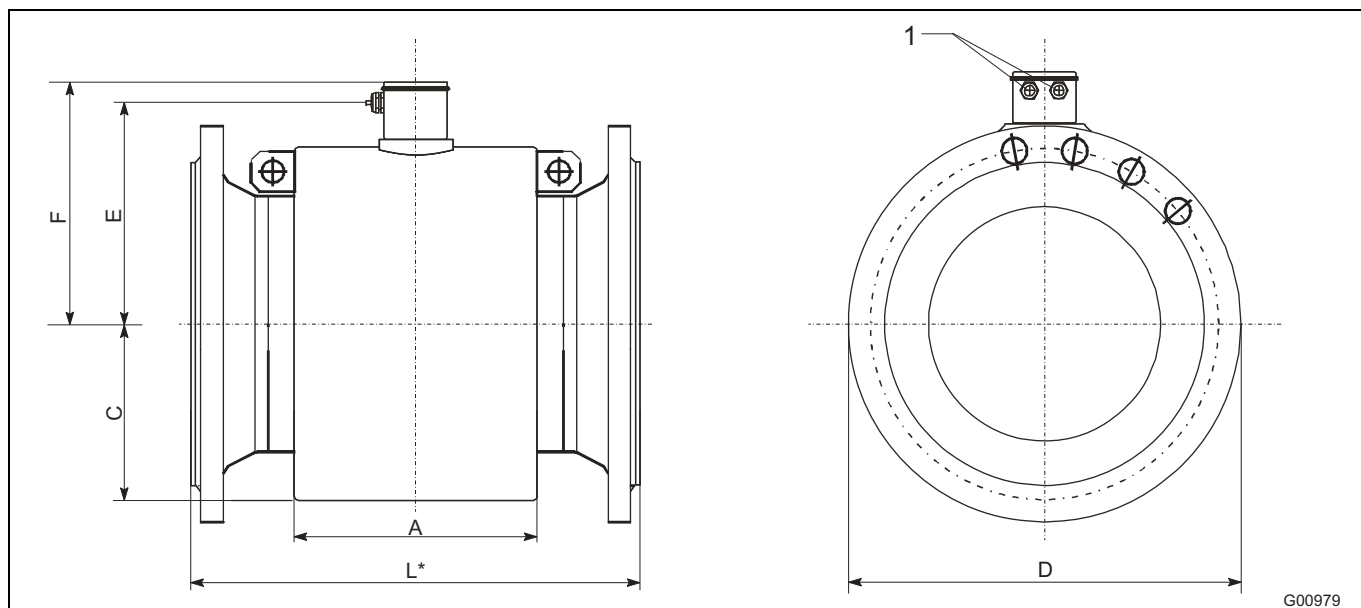

Fig. 24:

1 Cable gland M20 x 1.5 or NPT

Flange in acc. with DIN/EN 1092-1

Dimensions [mm]								Approx. weight [kg]
DN	PN 1)	D	L 2) 3)	F	C	E	A	
350	10	505	550	341	250	313	322	126
	16	520	550	341	250	313	322	140
400	10	565	600	367	275	339	370	155
	16	280	600	367	275	339	370	175
500	10	670	650	403	310	375	407	188
	16	715	650	403	310	375	407	238
600	10	780	780	454	361	426	469	338
	16	840	780	454	361	426	469	316
700	10	895	910	495	405	469	537	318
	16	910	910	495	405	469	537	438
800	10	1015	1040	545	455	519	605	418
	16	1025	1040	545	455	519	605	488
900	10	1115	1170	595	505	569	671	503
	16	1125	1170	595	505	569	671	588
1000	10	1230	1300	645	555	619	739	688
	16	1255	1300	645	555	619	739	848

Tolerance L: DN 350 +0 / -5 mm, DN 600 ... 1000+0 / -10 mm

Dimensions [inch]								Approx. weight [lb]
DN (inch)	PN 1)	D	L 2) 3)	F	C	E	A	
350 (14)	10	19.88	21.65	13.43	9.84	12.32	12.68	277.78
	16	20.47	21.65	13.43	9.84	12.32	12.68	308.64
400 (16)	10	22.24	23.62	14.45	10.83	13.35	14.57	341.71
	16	11.02	23.62	14.45	10.83	13.35	14.57	385.80
500 (20)	10	26.38	25.59	15.87	12.20	14.76	16.02	414.49
	16	28.15	25.59	15.87	12.20	14.76	16.02	524.73
600 (24)	10	30.71	30.71	17.87	14.21	16.77	18.46	745.20
	16	33.07	30.71	17.87	14.21	16.77	18.46	696.70
700 (28)	10	35.24	35.83	19.49	15.94	18.46	21.14	701.11
	16	35.83	35.83	19.49	15.94	18.46	21.14	965.67
800 (32)	10	39.96	40.94	21.46	17.91	20.43	23.82	921.58
	16	40.35	40.94	21.46	17.91	20.43	23.82	1075.91
900 (36)	10	43.90	46.06	23.43	19.88	22.40	26.42	1108.98
	16	44.29	46.06	23.43	19.88	22.40	26.42	1296.39
1000 (40)	10	48.43	51.18	25.39	21.85	24.37	29.09	1516.86
	16	49.41	51.18	25.39	21.85	24.37	29.09	1869.62

Tolerance L: DN 350 +0 / -0.197 inch, DN 600 ... 1000 +0 / -0.394 inch

Flange up to DN 600 (24") in acc. with ASME B16.5, flange DN 700 ... 1000 (28 ... 40") in acc. with ASME B16.47, Series B

Dimensions [mm]								Approx. weight [kg]
		CL150	Installation length					
DN	Inch	D	L ^{2) 3)}	F	C	E	A	
350	14	534	550	341	250	313	322	178
400	16	597	600	367	275	329	370	225
450	18	635	686	403	310	375	407	258
500	20	699	762	403	310	375	416	298
600	24	813	914	454	361	423	469	423
700	28	837	910	495	405	469	537	348
800	32	942	1040	545	455	519	605	498
900	36	1057	1170	595	505	569	671	678
1000	40	1380	1300	645	555	619	739	878

Tolerance L: DN 350 ... 500 +0 / -5 mm, DN 600 ... 1000+0 / -10 mm

Dimensions [inch]								Approx. weight [lb]
		CL150	Installation length					
DN	Inch	D	L ^{2) 3)}	F	C	E	A	
350	14	21.02	21.65	13.43	9.84	12.32	12.68	392.42
400	16	23.5	23.62	14.45	10.83	12.95	14.57	496.04
450	18	25.00	27.01	15.87	12.20	14.76	16.02	568.82
500	20	27.52	30.00	15.87	12.20	14.76	16.38	657.01
600	24	32.01	35.98	17.87	14.21	16.65	18.46	932.60
700	28	32.95	35.83	19.49	15.94	18.46	21.14	767.25
800	32	37.09	40.94	21.46	17.91	20.43	23.82	1097.96
900	36	41.61	46.06	23.43	19.88	22.40	26.42	1494.81
1000	40	54.33	51.18	25.39	21.85	24.37	29.09	1935.76

Tolerance L: DN 350 ... 500 +0 / -0.197 inch, DN 600 ... 1000 +0 / -0.394 inch

1) Other pressure ratings available on request.

2) If a grounding plate is installed (attached to one side of the flange), this increases dimension L as follows: DN 350 ... 600 um 5 mm (0.197 inch).

3) If protection plates are installed (attached to both sides of the flange), this increases dimension L as follows: DN 350 ... 600 by 10 mm (0.394 inch).

3.2.4 Flange DN 15 ... 200 (1/2 ... 8"), high-pressure versions PN 63 and PN 100

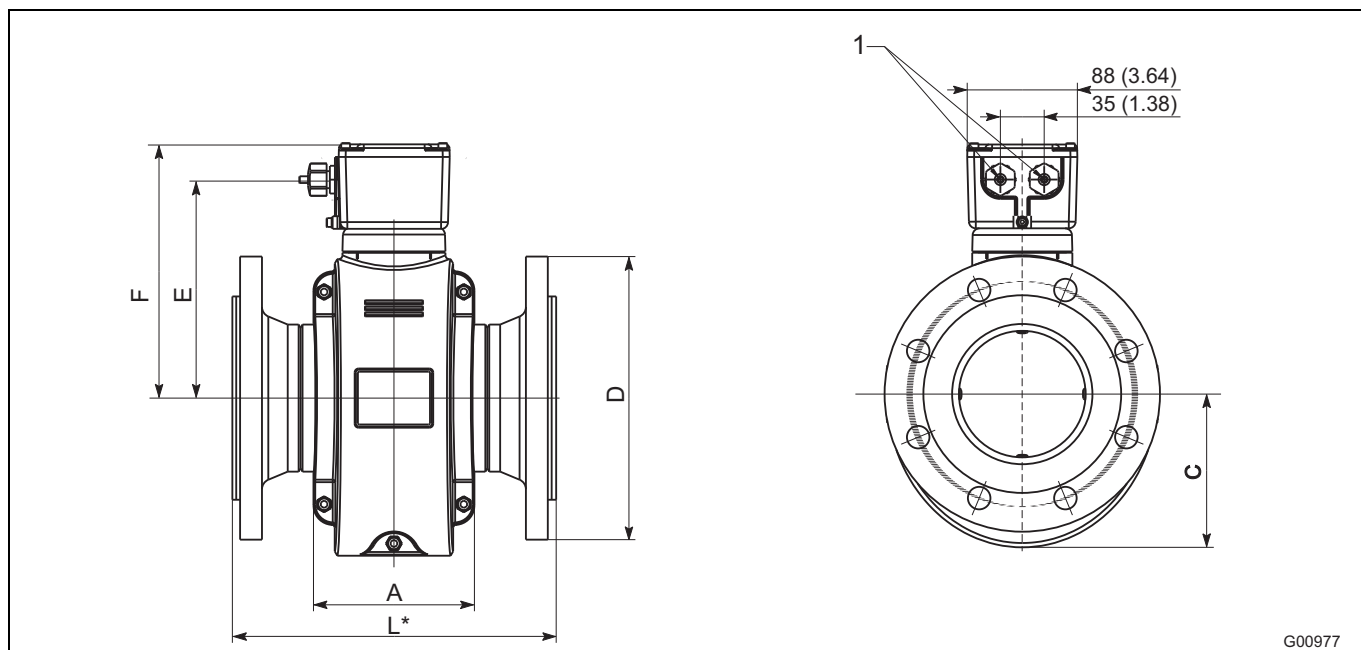

Fig. 25: Dimensions in mm (inch)

1 Cable gland M20 x 1.5 or NPT

Flange in acc. with DIN 2636 (PN 63) and DIN 2637 (PN 100)

Dimensions [mm (inch)] / [kg (lb)]								
DN	PN	D	L ^{1) 2)}	F ³⁾	C	E ³⁾	A	Approx. weight
15	63 ... 100	105 (4.13)	270 (10.63)	154 (6.06)	82 (3.23)	126 (4.96)	113 (4.45)	8 (17.64)
25	63 ... 100	140 (5.51)	270 (10.63)	154 (6.06)	82 (3.23)	126 (4.96)	113 (4.45)	10 (22.05)
40	63 ... 100	170 (6.69)	280 (11.02)	161 (6.34)	92 (3.62)	133 (5.24)	113 (4.45)	12 (26.46)
50	63	180 (7.09)	280 (11.02)	167 (6.57)	97 (3.82)	139 (5.47)	115 (4.53)	13 (28.66)
	100	195 (7.68)	280 (11.02)	167 (6.57)	97 (3.82)	139 (5.47)	115 (4.53)	16 (35.27)
65	63	205 (8.07)	330 (12.99)	178 (7.01)	108 (4.25)	150 (5.91)	104 (4.09)	16 (35.27)
	100	220 (8.66)	330 (12.99)	178 (7.01)	108 (4.25)	150 (5.91)	104 (4.09)	21 (46.30)
80	63	215 (8.46)	340 (13.39)	178 (7.01)	108 (4.25)	150 (5.91)	104 (4.09)	20 (44.09)
	100	230 (9.06)	340 (13.39)	178 (7.01)	108 (4.25)	150 (5.91)	104 (4.09)	24 (52.91)
100	63	250 (9.84)	400 (15.75)	200 (7.87)	122 (4.8)	172 (6.77)	125 (4.92)	27 (59.52)
	100	265 (10.43)	400 (15.75)	200 (7.87)	122 (4.8)	172 (6.77)	125 (4.92)	36 (79.37)

Continued on next page

Continued

Dimensions [mm (inch)]							
DN	PN	D	L ^{1) 2)}	F ³⁾	C	E ³⁾	A
125	63	295 (11.61)	450 (17.72)	210 (8.27)	130 (5.12)	182 (7.17)	125 (4.92)
	100	315 (12.4)	450 (17.72)	210 (8.27)	130 (5.12)	182 (7.17)	125 (4.92)
150	63	345 (13.58)	450 (17.72)	257 (10.12)	146 (5.75)	229 (9.02)	166 (6.54)
	100	355 (13.98)	450 (17.72)	257 (10.12)	146 (5.75)	229 (9.02)	166 (6.54)
200	63	415 (16.34)	500 (19.69)	283 (11.14)	170 (6.69)	255 (10.04)	200 (7.87)
	100	430 (16.93)	500 (19.69)	283 (11.14)	170 (6.69)	255 (10.04)	200 (7.87)

Tolerance L: +0 / -3 mm (+0 / -0.018 inch)

- 1) If a grounding plate is installed (attached to one side of the flange), this increases dimension L as follows: DN 3 ... 100 by 3 mm (0.118 inch), DN 125 and above by 5 mm (0.197 inch).
 2) If protection plates are installed (attached to both sides of the flange), this increases dimension L as follows: DN 3 ... 100 by 6 mm (0.236 inch), DN 125 and above by 10 mm (0.394 inch).
 3) Depending on the device design, the dimensions change according to the following table.

Device design	Dimension E, F
Standard temperature design	0
High temperature version	+127 mm (+5 inch)

3.2.5 Flange DN 15 ... 200 (1/2 ... 8"), high-pressure version CL 600

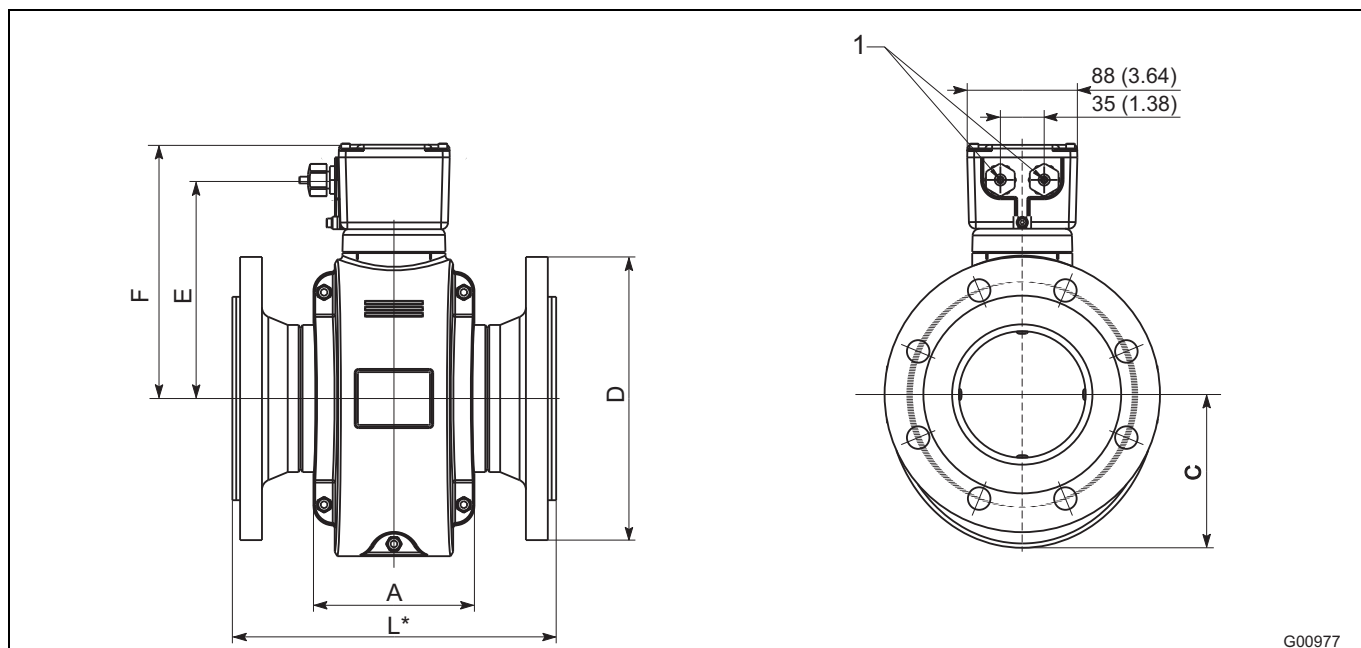

Fig. 26: Dimensions in mm (inch)
 1 Cable gland M20 x 1.5 or NPT

Flange in acc. with ASME B16.5, CL 600

Dimensions [mm (inch)] / [kg (lb)]								
DN	PN 1)	D	L 1) 2)	F 3)	C	E 3)	A	Approx. weight
15 (1/2)	CL 600	95 (3.75)	270 (10.63)	154 (6.06)	82 (3.23)	126 (4.96)	113 (4.45)	10 22.05
25 (1)	CL 600	124 (4.88)	270 (10.63)	154 (6.06)	82 (3.23)	126 (4.96)	113 (4.45)	10 22.05
40 (1 1/2)	CL 600	156 (6.15)	280 (11.02)	161 (6.34)	92 (3.62)	133 (5.24)	113 (4.45)	11 24.25
50 (2)	CL 600	165 (6.5)	280 (11.02)	167 (6.57)	97 (3.82)	139 (5.47)	115 (4.53)	13 28.66
65 (2 1/2)	CL 600	190 (7.5)	330 (12.99)	178 (7.01)	108 (4.25)	150 (5.91)	104 (4.09)	18 39.68
80 (3)	CL 600	210 (8.25)	340 (13.39)	178 (7.01)	108 (4.25)	150 (5.91)	104 (4.09)	23 50.71
100 (4)	CL 600	273 (10.75)	400 (15.75)	200 (7.87)	122 (4.8)	172 (6.77)	125 (4.92)	44 97.00
125 (5)	CL 600	330 (13)	450 (17.72)	210 (8.27)	130 (5.12)	182 (7.17)	125 (4.92)	On request
150 (6)	CL 600	355 (14)	450 (17.72)	257 (10.12)	146 (5.75)	229 (9.02)	166 (6.54)	On request
200 (8)	CL 600	420 (16.54)	500 (19.69)	283 (11.14)	170 (6.69)	255 (10.04)	200 (7.87)	On request

Tolerance L: +0 / -3 mm (+0 / -0.018 inch)

- 1) If a grounding plate is installed (attached to one side of the flange), this increases dimension L as follows: DN 3 ... 100 by 3 mm (0.118 inch), DN 125 and above by 5 mm (0.197 inch).
- 2) If protection plates are installed (attached to both sides of the flange), this increases dimension L as follows: DN 3 ... 100 by 6 mm (0.236 inch), DN 125 and above by 10 mm (0.394 inch).
- 3) Depending on the device design, the dimensions change according to the following table.

Device design	Dimension E, F
Standard temperature design	0
High temperature version	+127 mm (+5 inch)

3.3 Ordering information

Information on 3A conformity: If 3A conformity is desired, please order model SE21

Welded Flange, Liner Material Thick-PTFE / PTFE / PFA / ETFE

		Main order number																											Add. order no.			
Version number	1 - 6	7	8	9	10	11	12	13	14	15	16	17	18	19	20	21	22	23	24	25	26	27	28									
Electromagnetic Flowmeter	SE41F-	X	X	X	X	X	X	X	X	X	X	X	X	X	X	X	X	X	X	X	X	X	X	X	X	XX						
FSM4000																										XX						
Liner Material / Meter Size																																
PFA / DN 3 (1/10 in.)		P	0	3																												
PFA / DN 4 (5/32 in.)		P	0	4																												
PFA / DN 6 (1/4 in.)		P	0	6																												
PFA / DN 8 (5/16 in.)		P	0	8																												
PFA / DN 10 (3/8 in.)		P	1	0																												
PFA / DN 15 (1/2 in.)		P	1	5																												
PFA / DN 20 (3/4 in.)		P	2	0																												
PFA / DN 25 (1 in.)		P	2	5																												
PFA / DN 32 (1-1/4 in.)		P	3	2																												
PFA / DN 40 (1-1/2 in.)		P	4	0																												
PFA / DN 50 (2 in.)		P	5	0																												
PFA / DN 65 (2-1/2 in.)		P	6	5																												
PFA / DN 80 (3 in.)		P	8	0																												
PFA / DN 100 (4 in.)		P	1	H																												
PFA / DN 125 (5 in.)		P	1	Q																												
PFA / DN 150 (6 in.)		P	1	F																												
PFA / DN 200 (8 in.)		P	2	H																												
PTFE / DN 10 (3/8 in.)		T	1	0																												
PTFE / DN 15 (1/2 in.)		T	1	5																												
PTFE / DN 20 (3/4 in.)		T	2	0																												
PTFE / DN 25 (1 in.)		T	2	5																												
PTFE / DN 32 (1-1/4 in.)		T	3	2																												
PTFE / DN 40 (1-1/2 in.)		T	4	0																												
PTFE / DN 50 (2 in.)		T	5	0																												
PTFE / DN 65 (2-1/2 in.)		T	6	5																												
PTFE / DN 80 (3 in.)		T	8	0																												
PTFE / DN 100 (4 in.)		T	1	H																												
PTFE / DN 125 (5 in.)		T	1	Q																												
PTFE / DN 150 (6 in.)		T	1	F																												
PTFE / DN 200 (8 in.)		T	2	H																												
PTFE / DN 250 (10 in.)		T	2	F																												
PTFE / DN 300 (12 in.)		T	3	H																												
PTFE / DN 350 (14 in.)		T	3	F																												
PTFE / DN 400 (16 in.)		T	4	H																												
PTFE / DN 450 (18 in.)		T	4	F																												
PTFE / DN 500 (20 in.)		T	5	H																												
PTFE / DN 600 (24 in.)		T	6	H																												
Thick PTFE / DN 25 (1 in.)		F	2	5																												
Thick PTFE / DN 32 (1-1/4 in.)		F	3	2																												
Thick PTFE / DN 40 (1-1/2 in.)		F	4	0																												
Thick PTFE / DN 50 (2 in.)		F	5	0																												
Thick PTFE / DN 65 (2-1/2 in.)		F	6	5																												
Thick PTFE / DN 80 (3 in.)		F	8	0																												
Thick PTFE / DN 100 (4 in.)		F	1	H																												
Thick PTFE / DN 125 (5 in.)		F	1	Q																												
Thick PTFE / DN 150 (6 in.)		F	1	F																												
Thick PTFE / DN 200 (8 in.)		F	2	H																												
Thick PTFE / DN 250 (10 in.)		F	2	F																												
Thick PTFE / DN 300 (12 in.)		F	3	H																												
ETFE / DN 25 (1 in.)		E	2	5																												
ETFE / DN 32 (1-1/4 in.)		E	3	2																												
ETFE / DN 40 (1-1/4 in.)		E	4	0																												
ETFE / DN 50 (2 in.)		E	5	0																												
ETFE / DN 65 (2-1/2 in.)		E	6	5																												

Continued on next page

		Main order number																											Add. order no.
Version number		1-6	7	8	9	10	11	12	13	14	15	16	17	18	19	20	21	22	23	24	25	26	27	28	XX				
Electromagnetic Flowmeter FSM4000		SE41F-	X	X	X	X	X	X	X	X	X	X	X	X	X	X	X	X	X	X	X	X	X	X	X	X	XX		
Measuring Electrodes Material / Grounding Electrodes																													
Hastelloy C-4 (2.4610) / With					3)	O																							
Hastelloy B-3 (2.4600) / With					3)	N																							
AISI 316Ti SST (1.4571) / With					3)	E																							
Titanium / With					3)	I																							
Tantalum / With					3)	Q																							
AISI 904L SST (1.4539) / With					3)	R																							
Platinum-Iridium / With					3)	G																							
Nickel / With					4)	V																							
Double Layer / With					5)	D																							
Pressure Rating																													
PN 10, ISO lay length							C																						
PN 16, ISO lay length						6)	D																						
PN 25, ISO lay length							E																						
PN 40, ISO lay length						7)	F																						
JIS K10, ISO lay length						8)	K																						
ASME CL 150, ISO lay length							R																						
ASME CL 300, ISO lay length						9)	S																						
Others							Z																						
Material of Process Connection																													
Steel						10)	1																						
Stainless steel						11)	3																						
Accessories																													
Without							A																						
Protection rings AISI 316Ti SST (1.4571)						12)	B																						
Grounding ring AISI 316Ti SST (1.4571)						12)	C																						
Others							Z																						
Temperature Range																													
Standard design (<= 130 °C [266 °F])							S																						
High temperature design (<= 180 °C [356 °F])						13)	H																						
Certificates																													
PED Standard							A																						
Material certificate 3.1 acc. EN 10204 with pressure test						14)	D																						
AD2000																													
Pressure test AD2000							G																						
Inspection certificate 3.1 acc. EN 10204							F																						
Calibration Certificates																													
Standard							A																						
Fingerprint saved at factory						15)	F																						
Type of Protection / Cable Entry																													
IP 67 / Thread for screw-type conduit fitting M20 x 1.5																								2					
IP 67 / Thread for screw-type conduit fitting NPT 1/2 in.																								4					
IP 68 / Thread for screw-type conduit fitting M20 x 1.5																								16)	7				
IP 68 / Cable connected and connection box potted																									8				

Continued on next page

- 3) Grounding electrodes <= DN 400 (16 in.)
- 4) >= DN 25 (1 in.) / Grounding electrodes <= DN 400 (16 in.)
- 5) Basic material Hastelloy C4 / Grounding electrodes <= DN 400 (16 in.)
- 6) DN 65 (2-1/2 in.) / PN 16 with connection dimensions acc. EN 1092-1: Please order PN 40
- 7) Standard for DN 3 ... DN 80 (1/10 ... 3 in.)
- 8) <= DN 300 (12 in.)
- 9) <= DN 600 (24 in.)
- 10) >= DN 20 (3/4 in.)
- 11) Standard for DN 3 ... DN 15 (1/10 ... 1/2 in.), option from DN 20 (3/4 in.)
- 12) Protection rings mounted on both sides and ground rings mounted on one side to flange. Material SST 1.4571 (316Ti). Not available with grounding electrodes
- 13) only with Thick-PTFE/PFA >= DN 25 (1 in.)
- 14) Material certificate for meter tube and flanges
- 15) > DN8 (5/16 in.)
- 16) Sealing compound (optional): D141B038U01

		Main order number																												Add. order no.
Version number		1-6	7	8	9	10	11	12	13	14	15	16	17	18	19	20	21	22	23	24	25	26	27	28	XX					
Electromagnetic Flowmeter FSM4000		SE41F-	X	X	X	X	X	X	X	X	X	X	X	X	X	X	X	X	X	X	X	X	X	X	X	X	X	XX		
Design																														
Without pre-amplifier															17)	1														
With pre-amplifier type A															18)	2														
With pre-amplifier type B															19)	4														
Name Plate Language / Type																														
German / Adhesive foil															G															
English / Adhesive foil															E															
French / Adhesive foil															F															
German / Stainless steel															J															
English / Stainless steel															K															
French / Stainless steel															L															
Design Level																														
(Specified by ABB)															x															
Lay Length																														
Short, acc. ISO 13359																A														
Electrode Design																														
Standard																1														
Conical head, AISI 904L SST (1.4539)																20)	2													
Swedish design, Hastelloy C-4 (2.4610)																21)	3													
Signal Cable Length																														
Without cable																	0	0	0											
5 m (16 ft)																	0	0	5											
10 m (33 ft)																	0	1	0											
20 m (66 ft)																	0	2	0											
30 m (99 ft)																	0	3	0											
40 m (131 ft)																	0	4	0											
50 m (164 ft)																	0	5	0											
60 m (195 ft)																	0	6	0											
70 m (230 ft)																	0	7	0											
80 m (260 ft)																	0	8	0											
90 m (295 ft)																	0	9	0											
100 m (325 ft)																	1	0	0											
125 m (410 ft)																	1	2	5											
150 m (490 ft)																	1	5	0											
175 m (570 ft)																	1	7	5											
200 m (660 ft)																	2	0	0											
Excitation Cable Length																														
Without cable																	0	0	0											
5 m (16 ft)																	0	0	5											
10 m (33 ft)																	0	1	0											
20 m (66 ft)																	0	2	0											
30 m (99 ft)																	0	3	0											
40 m (131 ft)																	0	4	0											
50 m (164 ft)																	0	5	0											
60 m (195 ft)																	0	6	0											
70 m (230 ft)																	0	7	0											
80 m (260 ft)																	0	8	0											
90 m (295 ft)																	0	9	0											
100 m (325 ft)																	1	0	0											
125 m (410 ft)																	1	2	5											
150 m (490 ft)																	1	5	0											
175 m (570 ft)																	1	7	5											
200 m (660 ft)																	2	0	0											

Continued on next page

- 17) From DN 10 (3/8 in.) >= 20 µS/cm
- 18) Standard up to DN 8 (5/16 in.) >= 20 µS/cm, option > DN 8 (5/16 in.) >= 5 µS/cm and lay length max. 200 m (660 ft)
- 19) Option up to DN 8 (5/16 in.) >= 5 µS/cm, > DN 8 (5/16 in.) >= 0.5 µS/cm and lay length max. 200 m (660 ft)
- 20) For application e.g. with high fat contents
- 21) DN 50 ... DN 300 (2 ... 12 in.), for pulp applications with high resin contents

		Main order number																							XX	
Version number	1 – 6	7	8	9	10	11	12	13	14	15	16	17	18	19	20	21	22	23	24	25	26	27	28			
Electromagnetic Flowmeter	SE41F-	X	X	X	X	X	X	X	X	X	X	X	X	X	X	X	X	X	X	X	X	X	X	X	XX	
FSM4000																										
Calibration																										
2 Points (Standard)																							VK			
3 Point Standard Calibration																							VC			
Witnessed Calibration, 5 Calibration Points																							22) VE			
5 Point Calibration acc. DKD																							22) VD			
Language of Documentation																										
German																							M1			
English																							M5			
Russian																							MB			
Language package Western Europe / Scandinavia (Languages DE, EN, DA, ES, FR, IT, NL, PT, FI, SV)																							ME			
Language package Eastern Europe (Languages DE, EL, CS, ET, LV, LT, HU, PL, SK, SL, RO, BG)																							MW			
Others																							MZ			
Other Usage Certifications																										
Russia, Metrological and GOST-R Certificate																							CG1			
Kazakhstan, Metrological and GOST-K Certificate																							CG2			
Ukraine, Metrological Certificate																							CG3			
Belarus, Metrological Certificate																							CG6			

22) Only available with FSM4000-S4 External Converter

Festflansch, Auskleidung Hartgummi, Weichgummi, Ceramic Carbide

		Main order number																											Add. order no.			
Version number	1 - 6	7	8	9	10	11	12	13	14	15	16	17	18	19	20	21	22	23	24	25	26	27	28									
Electromagnetic Flowmeter	SE41F-	X	X	X	X	X	X	X	X	X	X	X	X	X	X	X	X	X	X	X	X	X	X	X	X	XX						
FSM4000																										XX						
Liner Material / Meter Size																																
Hard Rubber / DN 15 (1/2 in.)		H	1	5																												
Hard Rubber / DN 20 (3/4 in.)		H	2	0																												
Hard Rubber / DN 25 (1 in.)		H	2	5																												
Hard Rubber / DN 32 (1-1/4 in.)		H	3	2																												
Hard Rubber / DN 40 (1-1/2 in.)		H	4	0																												
Hard Rubber / DN 50 (2 in.)		H	5	0																												
Hard Rubber / DN 65 (2-1/2 in.)		H	6	5																												
Hard Rubber / DN 80 (3 in.)		H	8	0																												
Hard Rubber / DN 100 (4 in.)		H	1	H																												
Hard Rubber / DN 125 (5 in.)		H	1	Q																												
Hard Rubber / DN 150 (6 in.)		H	1	F																												
Hard Rubber / DN 200 (8 in.)		H	2	H																												
Hard Rubber / DN 250 (10 in.)		H	2	F																												
Hard Rubber / DN 300 (12 in.)		H	3	H																												
Hard Rubber / DN 350 (14 in.)		H	3	F																												
Hard Rubber / DN 400 (16 in.)		H	4	H																												
Hard Rubber / DN 450 (18 in.)		H	4	F																												
Hard Rubber / DN 500 (20 in.)		H	5	H																												
Hard Rubber / DN 600 (24 in.)		H	6	H																												
Hard Rubber / DN 700 (28 in.)		H	7	H																												
Hard Rubber / DN 800 (32 in.)		H	8	H																												
Hard Rubber / DN 900 (36 in.)		H	9	H																												
Hard Rubber / DN 1000 (40 in.)		H	1	T																												
Soft Rubber / DN 50 (2 in.)		S	5	0																												
Soft Rubber / DN 65 (2-1/2 in.)		S	6	5																												
Soft Rubber / DN 80 (3 in.)		S	8	0																												
Soft Rubber / DN 100 (4 in.)		S	1	H																												
Soft Rubber / DN 125 (5 in.)		S	1	Q																												
Soft Rubber / DN 150 (6 in.)		S	1	F																												
Soft Rubber / DN 200 (8 in.)		S	2	H																												
Soft Rubber / DN 250 (10 in.)		S	2	F																												
Soft Rubber / DN 300 (12 in.)		S	3	H																												
Soft Rubber / DN 350 (14 in.)		S	3	F																												
Soft Rubber / DN 400 (16 in.)		S	4	H																												
Soft Rubber / DN 450 (18 in.)		S	4	F																												
Soft Rubber / DN 500 (20 in.)		S	5	H																												
Soft Rubber / DN 600 (24 in.)		S	6	H																												
Soft Rubber / DN 700 (28 in.)		S	7	H																												
Soft Rubber / DN 800 (32 in.)		S	8	H																												
Soft Rubber / DN 900 (36 in.)		S	9	H																												
Soft Rubber / DN 1000 (40 in.)		S	1	T																												
Ceramic-Carbide / DN 25 (1 in.)		1)	C	2	5																											
Ceramic-Carbide / DN 32 (1-1/4 in.)		1)	C	3	2																											
Ceramic-Carbide / DN 40 (1-1/2 in.)		1)	C	4	0																											
Ceramic-Carbide / DN 50 (2 in.)		1)	C	5	0																											
Ceramic-Carbide / DN 65 (2-1/2 in.)		1)	C	6	5																											
Ceramic-Carbide / DN 80 (3 in.)		1)	C	8	0																											
Ceramic-Carbide / DN 100 (4 in.)		1)	C	1	H																											
Ceramic-Carbide / DN 125 (5 in.)		1)	C	1	Q																											
Ceramic-Carbide / DN 150 (6 in.)		1)	C	1	F																											
Ceramic-Carbide / DN 200 (8 in.)		1)	C	2	H																											
Ceramic-Carbide / DN 250 (10 in.)		1)	C	2	F																											
Ceramic-Carbide / DN 300 (12 in.)		1)	C	3	H																											
Ceramic-Carbide / DN 350 (14 in.)		1)	C	3	F																											

Continued on next page

1) Nur mit Wolfram-Karbid Elektroden / Schutzscheiben beidseitig am Flansch befestigt. Material 1.4571 (316Ti)

		Main order number																												Add. order no.	
Version number		1	2	3	4	5	6	7	8	9	10	11	12	13	14	15	16	17	18	19	20	21	22	23	24	25	26	27	28	XX	
Electromagnetic Flowmeter SE41F-FSM4000		X	X	X	X	X	X	X	X	X	X	X	X	X	X	X	X	X	X	X	X	X	X	X	X	X	X	X	X	X	XX
Measuring Electrodes Material / Grounding Electrodes																															
Hastelloy C-4 (2.4610) / With																														4) O	
Hastelloy B-3 (2.4600) / With																														4) N	
AISI 316Ti SST (1.4571) / With																														4) E	
Titanium / With																														4) I	
Tantalum / With																														4) Q	
AISI 904L SST (1.4539) / With																														4) R	
Platinum-Iridium / With																														4) G	
Nickel / With																														5) V	
Double Layer / With																														6) D	
Pressure Rating																															
PN 10, ISO laid length																														C	
PN 16, ISO laid length																														7) D	
PN 25, ISO laid length																														E	
PN 40, ISO laid length																														8) F	
PN 63																														9) G	
PN 100																														9) H	
JIS K10, ISO laid length																														10) K	
ASME CL 150, ISO laid length																														R	
ASME CL 300, ISO laid length																														11) S	
ASME CL 600																														9) T	
Others																														Z	
Material of Process Connection																															
Steel																														12) 1	
Stainless steel																														13) 3	
Accessories																															
Without																														A	
Others																														Z	
Temperature Range																															
Standard design																														S	
Certificates																															
PED Standard																														A	
Material certificate 3.1 acc. EN 10204 with pressure test																														14) D	
AD2000																															
Pressure test AD2000																														G	
Inspection certificate 3.1 acc. EN 10204																														F	
Calibration Certificates																															
Standard																														A	
Fingerprint saved at factory																														15) F	
Type of Protection / Cable Entry																															
IP 67 / Thread for screw-type conduit fitting M20 x 1.5																														2	
IP 67 / Thread for screw-type conduit fitting NPT 1/2 in.																														4	
IP 68 / Thread for screw-type conduit fitting M20 x 1.5																														16) 7	
IP 68 / Cable connected and connection box potted																														8	

Continued on next page

- 4) Grounding electrodes <= DN 400 (16 in.)
- 5) >= DN 25 (1 in.) / Grounding electrodes <= DN 400 (16 in.)
- 6) Basic material Hastelloy C4 / Grounding electrodes <= DN 400 (16 in.)
- 7) DN 65 (2-1/2 in.) / PN 16 with connection dimensions acc. EN 1092-1: Please order PN 40
- 8) Standard for DN 15 ... DN 80 (1/2 ... 3 in.)
- 9) <= DN 200 (8 in.) / Hardrubber only
- 10) <= DN 300 (12 in.)
- 11) <= DN 600 (24 in.)
- 12) >= DN 20 (3/4 in.)
- 13) Standard for DN 3 ... DN 15 (1/10 ... 1/2 in.), option from DN 20 (3/4 in.)
- 14) Material certificate for meter tube and flanges
- 15) > DN8 (5/16 inch)
- 16) Sealing compound (optional): D141B038U01

		Main order number																											Add. order no.			
Version number		1	2	3	4	5	6	7	8	9	10	11	12	13	14	15	16	17	18	19	20	21	22	23	24	25	26	27	28	XX		
Electromagnetic Flowmeter FSM4000		SE41F-	X	X	X	X	X	X	X	X	X	X	X	X	X	X	X	X	X	X	X	X	X	X	X	X	X	X	X	X	XX	
Design																																
Without pre-amplifier																			17)	1												
With pre-amplifier type A																			18)	2												
With pre-amplifier type B																			19)	4												
Name Plate Language / Type																			G													
German / Adhesive foil																			E													
English / Adhesive foil																			F													
French / Adhesive foil																			J													
German / Stainless steel																			K													
English / Stainless steel																			L													
French / Stainless steel																																
Design Level																			x													
(Specified by ABB)																																
Laid Length																														A		
Short, acc. ISO 13359																																
Electrode Design																														1		
Standard																																
Conical head, AISI 904L SST (1.4539)																			20)	2												
Signal Cable Length																														0	0	0
Without cable																																
5 m (16 ft)																														0	0	5
10 m (33 ft)																														0	1	0
20 m (66 ft)																														0	2	0
30 m (99 ft)																														0	3	0
40 m (131 ft)																														0	4	0
50 m (164 ft)																														0	5	0
60 m (195 ft)																														0	6	0
70 m (230 ft)																														0	7	0
80 m (260 ft)																														0	8	0
90 m (295 ft)																														0	9	0
100 m (325 ft)																														1	0	0
125 m (410 ft)																														1	2	5
150 m (490 ft)																														1	5	0
175 m (570 ft)																														1	7	5
200 m (660 ft)																														2	0	0
Excitation Cable Length																														0	0	0
Without cable																																
5 m (16 ft)																														0	0	5
10 m (33 ft)																														0	1	0
20 m (66 ft)																														0	2	0
30 m (99 ft)																														0	3	0
40 m (131 ft)																														0	4	0
50 m (164 ft)																														0	5	0
60 m (195 ft)																														0	6	0
70 m (230 ft)																														0	7	0
80 m (260 ft)																														0	8	0
90 m (295 ft)																														0	9	0
100 m (325 ft)																														1	0	0
125 m (410 ft)																														1	2	5
150 m (490 ft)																														1	5	0
175 m (570 ft)																														1	7	5
200 m (660 ft)																														2	0	0

Continued on next page

- 17) $\geq 20 \mu\text{S/cm}$
- 18) Option $\geq 5 \mu\text{S/cm}$ and lay length max. 200 m (660 ft)
- 19) Option $\geq 0.5 \mu\text{S/cm}$ and lay length max. 200 m (660 ft)
- 20) For application e.g. with high fat contents

		Main order number																						Add. order no.
Version number	1 – 6	7	8	9	10	11	12	13	14	15	16	17	18	19	20	21	22	23	24	25	26	27	28	XX
Electromagnetic Flowmeter	SE41F-	X	X	X	X	X	X	X	X	X	X	X	X	X	X	X	X	X	X	X	X	X	X	XX
FSM4000																								
Calibration																								
2 Points (Standard)																						VK		
3 Point Standard Calibration																						VC		
Witnessed Calibration, 5 Calibration Points																						21) VE		
5 Point Calibration acc. DKD																						21) VD		
Language of Documentation																								
German																						M1		
English																						M5		
Russian																						MB		
Language package Western Europe / Scandinavia (Languages DE, EN, DA, ES, FR, IT, NL, PT, FI, SV)																						ME		
Language package Eastern Europe (Languages DE, EL, CS, ET, LV, LT, HU, PL, SK, SL, RO, BG)																						MW		
Others																						MZ		
Other Usage Certifications																								
Russia, Metrological and GOST-R Certificate																						CG1		
Kazakhstan, Metrological and GOST-K Certificate																						CG2		
Ukraine, Metrological Certificate																						CG3		
Belarus, Metrological Certificate																						CG6		

21) Only available with FSM4000-S4 External Converter

4 Model SE21_

4.1 Specifications

Minimum Allowable Absolute Pressure

Lining	Nominal diameter DN	P _{Operation} mbar abs	at	T _{Operating} ¹ °C
PFA	3 ... 100 (1/10 ... 4")	0	≤	130 °C (266 °F)
Peek/Torlon	1 ... 2 (1/25 ... 1/12")	0	≤	120 °C (248 °F)

1) Higher temperatures are allowed for CIP / SIP cleaning for limited time periods, see the table titled "Max. allowable cleaning temperature".

Maximum Allowable Cleaning Temperature

CIP cleaning	Lining	T _{max} °C	T _{max} Minutes	T _{amb.} °C
Steam cleaning	PFA / Peek	150 °C (302 °F)	60	25 °C (77 °F)
Wet cleaning	PFA / Peek / Torlon	140 °C (284 °F)	60	25 °C (77 °F)

If the ambient temperature is > 25 °C (77 °F), then the difference must be subtracted from the max. cleaning temperature.

$$T_{max} - \Delta \text{ °C}, \Delta \text{ °C} = (T_{amb} - 25 \text{ °C})$$

Maximum Allowable Temperature Shock

Lining	Temp Shock max. Temp. Diff. °C	Temp. gradient °C/min
PFA	Any	Any
Peek, Torlon	Any	Any

Maximum allowable ambient temperature as function of fluid temperature

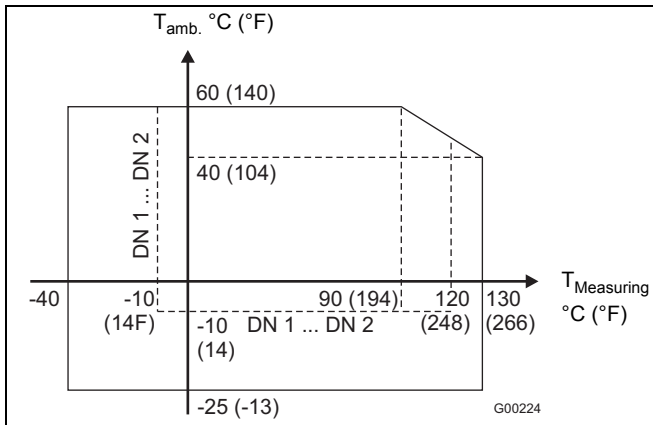

Fig. 27: Temperature graph

The flowmeter sensor must not be isolated.

Fluid temperature DN 1 ... DN 2 (1/25 ... 1/12")

-10 ... 120 °C (14 ... 248 °F), max. allowable cleaning temperature, see table.

Flowmeter material

Lining	Electrode material		Electrode design	
	Standard	Others	Standard	Others
PFA, Peek, Torlon	Hast.-C4 (2.4610) (1.4539 [904 L] for pipe conn. and Tri-Clamp)	Hast.-B3 (2.4600), 1.4539 (904 L), 1.4571 (316 Ti), Titanium, tantalum, Platinum-iridium	Flat head	Pointed head (≥ DN 10) 1.4539 (904 L)

1/8" sanitary connectors always with 2 grounding electrodes in material for signal electrodes, standard.

Process connection material

Process connection	Standard	Option
Flange	Stainless steel 1.4571 (316 Ti)	On rqst.
Wafer type	None	
Weld stubs	Stainless steel 1.4404 (316 L)	On rqst.
Threaded pipe connection	Stainless steel 1.4404 (316 L)	On rqst.
Tri-Clamp	Stainless steel 1.4404 (316 L)	On rqst.
External threads	Stainless steel 1.4404 (316 L)	On rqst.
1/8" sanitary connectors	Stainless steel 1.4571 (316 Ti)	POM, brass, PVC
Terminal box	Stainless steel 1.4301 (304)	-
- without/with preamplifier, type A	Al alloy, painted, paint coat frame: dark gray, RAL 7012 cover: light gray, RAL 9002	-
- with preamplifier, type B		
Meter tube	Stainless steel 1.4301 (304)	-
cable gland used	Polyamide	PVDF
Flowmeter sensor housing	Stainless steel 1.4301 (304)	-

Gasket material (internal)

Process connection	Standard	Option
Wafer type	None	-
Weld stubs	EPDM (Ethylene-Propylene) with FDA approval, silicone with FDA approval (CIP-resistant, no oils or grease)	Silicon with FDA approval (optional, resistant to oils and grease)
Threaded pipe connection		
Tri-Clamp		
External threads		PTFE with FDA approval (DN 3 ... 8)
1/8" sanitary connectors	PTFE	Viton (only in combination with PVC process connection)
Flat gaskets	Silicon (resistant to oil, grease)	-

Storage temperature

-25 ... 70 °C (-13 ... 158 °F)

Degree of protection acc. to EN 60529

- IP 67
- IP 68 (option)

Pipeline vibration according to EN 60068-2-6

Transmitter

- In the range of 10...55 Hz, max. deflection 0.15 mm

Flowmeter sensor

- In the range of 10...55 Hz, max. deflection 0.15 mm

- In the range of 55...150 Hz, max. acceleration 2 g

Material load for meters with variable process connections / wafer type SE21 DN 1 ... DN 100 (1/25 ... 4")

Process connection	Nominal diameter DN	PS _{max} [bar]	TS _{min}	TS _{max}
Liner PFA Wafer type	3 ... 50 (1/10 ... 2")	40	-40 °C (-40 °F)	130 °C (266 °F)
	65 ... 100 (2 1/2 ... 4")	16		
Weld stubs	3 ... 40 (1/10 ... 1 1/2")	40		
	50; 80 (2", 3")	16	-25 °C (-13 °F)	130 °C (266 °F)
	65, 100 (2 1/2 ... 4")	10		
Threaded pipe connection conforming to DIN 11851	3 ... 40 (1/10 ... 1 1/2")	40		
	50; 80 (2", 3")	16	-25 °C (-13 °F)	130 °C (266 °F)
	65, 100 (2 1/2 ... 4")	10		
Tri-Clamp conforming to DIN 32676	3 ... 50 (1/10 ... 2")	16	-25 °C (-13 °F)	121 °C (250 °F)
	65 ... 100 (2 1/2 ... 4")	10		
Tri-Clamp in acc. with ASME BPE	3 ... 100 (1/10 ... 4")	10	-25 °C (-13 °F)	130 °C (266 °F)
External threads ISO 228	3 ... 25 (1/10 ... 1")	16	-25 °C (-13 °F)	130 °C (266 °F)
1/8" sanitary connectors	1 ... 2 (1/25 ... 1/12")	10	-10 °C (14 °F)	120 °C (248 °F)

JIS B2210-10K wafer type

Meter size DN	Material	PN	TS	PS [bar]
32 ... 100 (1¼ ... 4")	1.4404 (316 L), 1.4435 (316 L), 1.4301 (304)	10	-40 ... 130 °C (-40 ... 266 °F)	10

Material load for flange model SE21F

Lining: PFA

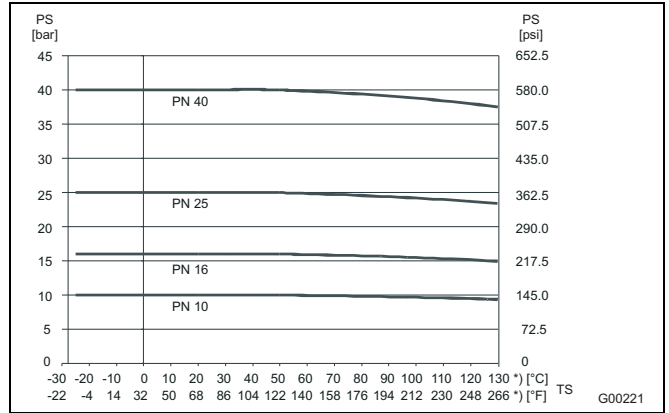

Fig. 28: DIN flange, stainless steel 1.4571 (316 Ti) up to DN 100 (4")

Liner PFA

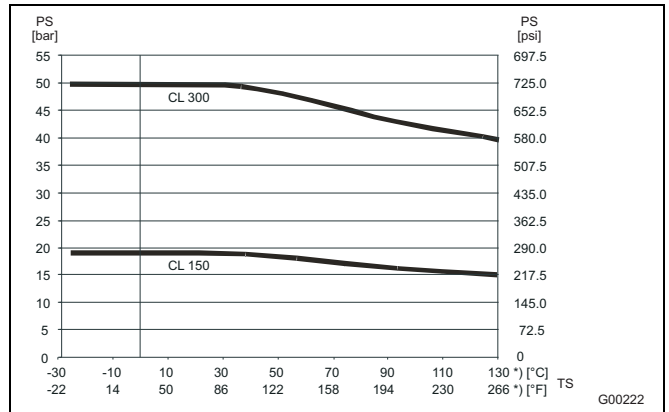

Fig. 29: ASME flange, stainless steel 1.4571 (316 Ti) up to DN 100 (4")

Material load for flange model SE21W

Lining: PFA wafer type

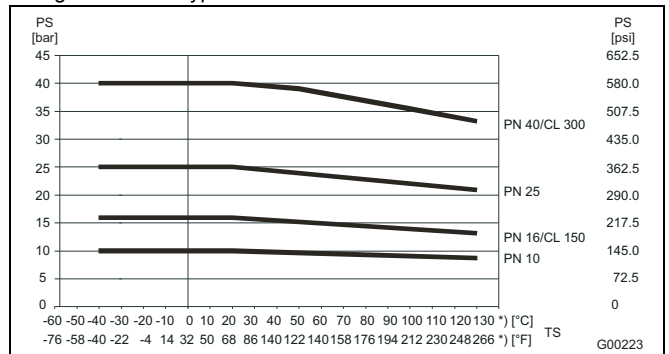

Fig. 30

*) For CIP / SIP cleaning, higher temperatures are permitted for limited time periods; refer to the table titled "Maximum permissible cleaning temperature".

4.2 Dimensions

4.2.1 Model SE21F

Stainless steel housing, flange acc. to DIN / EN 1092-1, DN 3 ... DN 40; ASME B16.5, 1/10 ... 1 1/2"

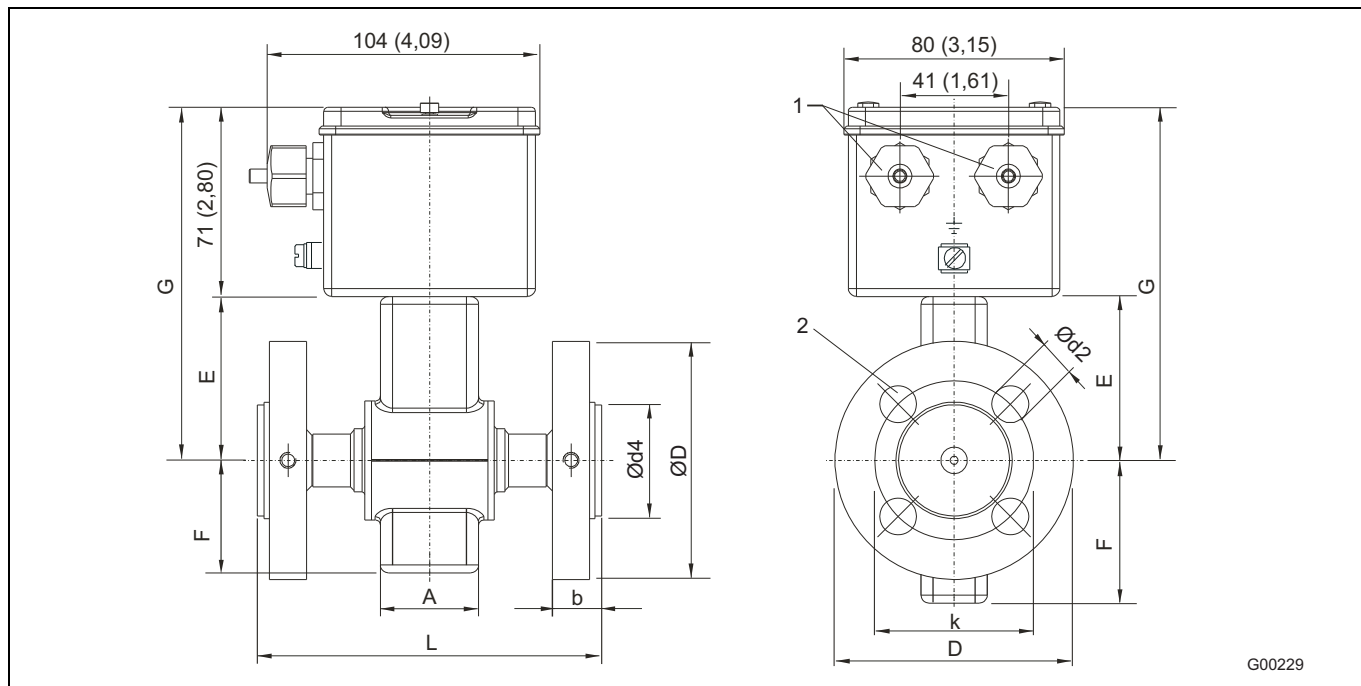

Fig. 31: Dimensions in mm (inch)

- 1 Cable gland M20 x 1.5 or NPT
- 2 Number of holes N

DN	PN	Flange dimensions acc. to DIN / EN, liner PFA										Weight
		mm										approx. kg
		L ¹⁾	A	D	k	d4	d2	b	E	F	G	
3 ... 8 ³⁾	10 ... 40	130	37	90	60	42	14	18	62	39	133	2.5
10, 15		200	37	90.95	65	36	14	18	62	39	133	2.5
20		200	42	105	75	41	14	20	66	43	137	2.5
25		200	54	115	85	54	14	20	73	48	144	3
32		200	62	140	100	64	14	20	78	53	149	4
40		200	67	150	110	74	14	20	82	57	153	4.5
DN	PN	inch										Approx. lb
3 ... 8 ³⁾	10 ... 40	5.12	1.46	3.54	2.36	1.65	0.55	0.71	2.44	1.54	5.24	5.5
10, 15		7.87	1.46	3.54, 3.74	2.56	1.42	0.55	0.71	2.44	1.54	5.24	5.5
20		7.87	1.65	4.13	2.95	1.61	0.55	0.79	2.60	1.69	5.39	5.5
25		7.87	2.13	4.53	3.35	2.13	0.55	0.79	2.87	1.89	5.67	6.6
32		7.87	2.44	5.51	3.94	2.52	0.55	0.79	3.07	2.09	5.87	8.8
40		7.87	2.64	5.91	4.33	2.91	0.55	0.79	3.23	2.24	6.02	9.9

- 1) If a grounding plate is required, L + 3 mm (0.12"), material upon request. With 2 grounding plates (protection plates) L + 6 mm (0.24"), material upon request.
- 2) Connecting dimensions acc. to EN1092-1
- 3) Connection flange DN 10 (3/8")
- 4) Connection flange 1/2"

Inch	PN	Flange dimensions acc. to ASME B16.5, liner PFA										Weight
		mm										approx. kg
		L ¹⁾	A	D	k	d4	d2	b	E	F	G	
1/10 ... 5/16 ⁴⁾	CL 150	130	37	88.9	60.3	42.0	15.9	18.0	62	39	133	2.5
3/8 ⁴⁾ , 1/2		200	37	88.9	60.3	34.8	15.9	12.6	62	39	133	2.5
3/4		200	42	98.4	69.8	42.9	15.9	14.2	66	43	137	2.5
1		200	54	108.0	79.2	50.8	15.9	15.8	73	48	144	3
1 1/4		200	62	117.5	88.9	63.5	15.9	17.4	78	53	149	3
1 1/2		200	67	127.0	98.6	73.0	15.9	19.0	82	57	153	3.5
1/10 ... 5/16 ⁴⁾	CL 300	130	37	95.2	66.7	42.0	15.9	18.0	62	39	133	2.5
3/8 ⁴⁾ , 1/2		200	37	95.2	66.7	34.8	15.9	15.8	62	39	133	2.5
3/4		200	42	117.5	82.5	42.9	19.0	17.4	66	43	137	2.5
1		200	54	123.8	88.9	50.8	19.0	19.0	73	48	144	3
1 1/4		200	62	133.3	98.4	63.5	19.0	20.5	78	53	149	4
1 1/2		200	67	155.6	114.3	73.0	22.2	22.1	82	57	153	4.5
Inch	PN	inch										Approx. lb
1/10 ... 5/16 ⁴⁾	CL 150	5.12	1.46	3.50	2.37	1.65	0.63	0.71	2.44	1.54	5.24	5.5
3/8 ⁴⁾ , 1/2		7.87	1.46	3.50	2.37	1.37	0.63	0.50	2.44	1.54	5.24	5.5
3/4		7.87	1.65	3.87	2.75	1.69	0.63	0.56	2.60	1.69	5.39	5.5
1		7.87	2.13	4.25	3.12	2.00	0.63	0.62	2.87	1.89	5.67	6.6
1 1/4		7.87	2.44	4.63	3.50	2.50	0.63	0.69	3.07	2.09	5.87	6.6
1 1/2		7.87	2.64	5.00	3.88	2.87	0.63	0.75	3.23	2.24	6.02	7.7
1/10 ... 5/16 ⁴⁾	CL 300	5.12	1.46	3.75	2.63	1.65	0.63	0.71	2.44	1.54	5.24	5.5
3/8 ⁴⁾ , 1/2		7.87	1.46	3.75	2.63	1.37	0.63	0.62	2.44	1.54	5.24	5.5
3/4		7.87	1.65	4.63	3.25	1.69	0.75	0.69	2.60	1.69	5.39	5.5
1		7.87	2.13	4.87	3.50	2.00	0.75	0.75	2.87	1.89	5.67	6.6
1 1/4		7.87	2.44	5.25	3.87	2.50	0.75	0.81	3.07	2.09	5.87	8.8
1 1/2		7.87	2.64	6.13	4.50	2.87	0.87	0.87	3.23	2.24	6.02	9.9

- 1) If a grounding plate is required, L + 3 mm (0.12"), material upon request. With 2 grounding plates (protection plates) L + 6 mm (0.24"), material upon request.
- 2) Connecting dimensions acc. to EN1092-1
- 3) Connection flange DN 10 (3/8")
- 4) Connection flange 1/2"

Stainless steel housing, flange acc. to DIN / EN 1092-1, DN 50 ... DN 100; ASME B16.5, 2 ... 4"

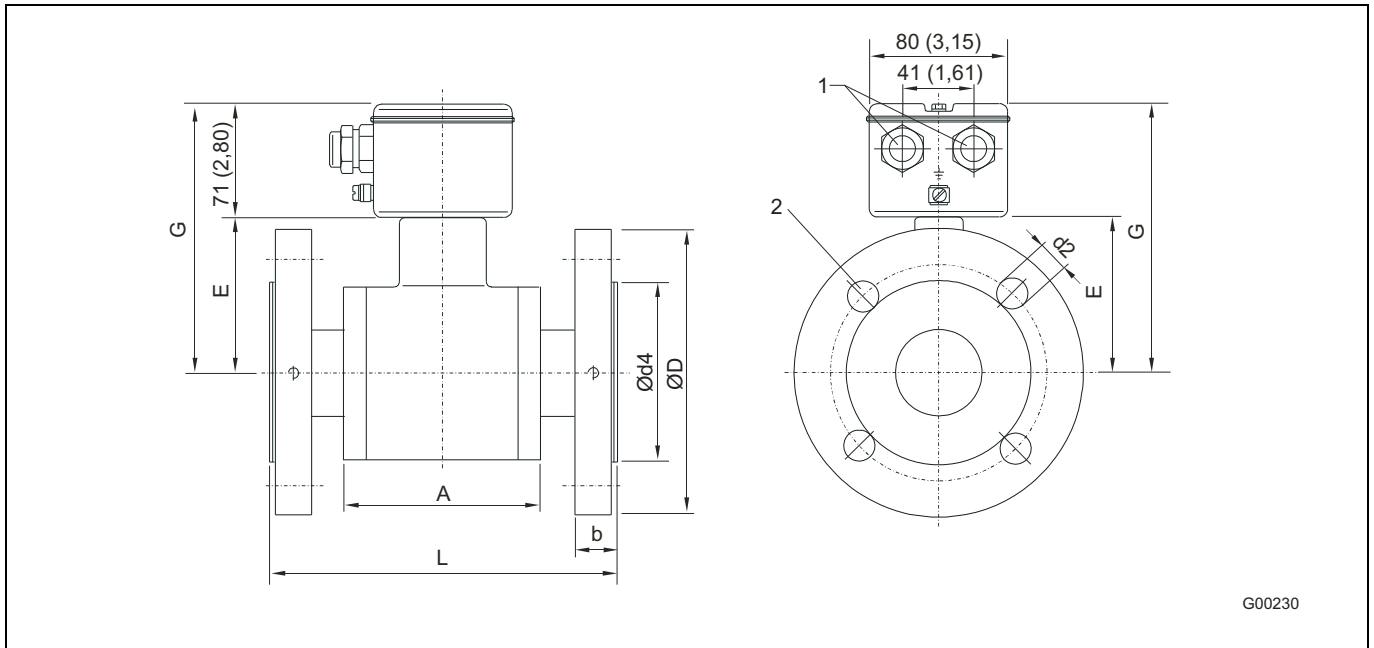

Fig. 32: Dimensions in mm (inch)
 1 Cable gland M20 x 1.5 or NPT
 2 Number of holes N

DN	PN	Flange dimensions acc. to DIN / EN, liner PFA										Weight
		mm										approx. kg
		L ¹⁾	A	D	k	d4	d2	N	b	E	G	
50	10 ... 40	200	100	165	125	104	18	4	24	90	161	8
65 ²⁾	10 ... 16	200	107	185	145	124	18	4	26	105	176	10
	25 ... 40	200	107	185	145	124	18	8	26	105	176	10
80	10 ... 40	200	107	200	160	139	18	8	28	114	185	12
100	10 ... 16	250	159	220	180	161	18	8	24	128	199	18
	25 ... 40	250	159	235	190	167	22	8	28	128	199	18
DN	PN	inch										Approx. lb
		L ¹⁾	A	D	k	d4	d2	N	b	E	G	
50	10 ... 40	7.87	3.94	6.50	4.92	4.09	0.71	0.16	0.94	3.54	6.34	17.6
65 ²⁾	10 ... 16	7.87	4.21	7.28	5.71	4.88	0.71	0.16	1.02	4.13	6.93	22.0
	25 ... 40	7.87	4.21	7.28	5.71	4.88	0.71	0.31	1.02	4.13	6.93	22.0
80	10 ... 40	7.87	4.21	7.87	6.30	5.47	0.71	0.31	1.10	4.49	7.28	26.5
100	10 ... 16	9.84	6.26	8.66	7.09	6.34	0.71	0.31	0.94	5.04	7.83	39.7
	25 ... 40	9.84	6.26	9.25	7.48	6.57	0.87	0.31	1.10	5.04	7.83	39.7

1) If a grounding plate is required, L + 3 mm (0.12"), material upon request. With 2 grounding plates (protection plates) L + 6 mm (0.24"), material upon request.
 2) For DN 65/PN 16 acc. to EN 1092-1 please order PN 40.

Inch	PN	Flange dimensions acc. to ASME B16.5, liner PFA										Weight
		mm										approx. kg
		L ¹⁾	A	D	k	d4	d2	N	b	E	G	
2	CL 150	200	100	152	121	99	19	4	23	90	161	8
2 1/2		200	107	178	140	118	19	4	26	105	176	10
3		200	107	191	152	131	19	4	28	114	185	12
4		250	159	229	190	171	19	8	28	128	199	18
2	CL 300	200	100	165	127	102	19	8	26	90	161	8
2 1/2		200	107	191	149	124	22	8	29	105	176	10
3		200	107	210	168	143	22	8	32	114	185	12
4		250	159	254	200	177	22	8	36	128	199	18
Inch	PN	inch										Approx. lb
		L ¹⁾	A	D	k	d4	d2	N	b	E	G	
2	CL 150	7.87	3.94	5.98	4.76	3.90	0.75	0.16	0.91	3.54	6.34	17.6
2 1/2		7.87	4.21	7.01	5.51	4.65	0.75	0.16	1.02	4.13	6.93	22.0
3		7.87	4.21	7.52	5.98	5.16	0.75	0.16	1.10	4.49	7.28	26.5
4		9.84	6.26	9.02	7.48	6.73	0.75	0.31	1.10	5.04	7.83	39.7
2	CL 300	7.87	3.94	6.50	5.00	4.02	0.75	0.31	1.02	3.54	6.34	17.6
2 1/2		7.87	4.21	7.52	5.87	4.88	0.87	0.31	1.14	4.13	6.93	22.0
3		7.87	4.21	8.27	6.61	5.63	0.87	0.31	1.26	4.49	7.28	26.5
4		9.84	6.26	10.00	7.87	6.97	0.87	0.31	1.42	5.04	7.83	39.7

1) If a grounding plate is required, L + 3 mm (0.12"), material upon request. With 2 grounding plates (protection plates) L + 6 mm (0.24"), material upon request.

4.2.2 Model SE21W

Stainless steel housing, wafer type DN 3 ... DN 100 (1/10 ... 4")

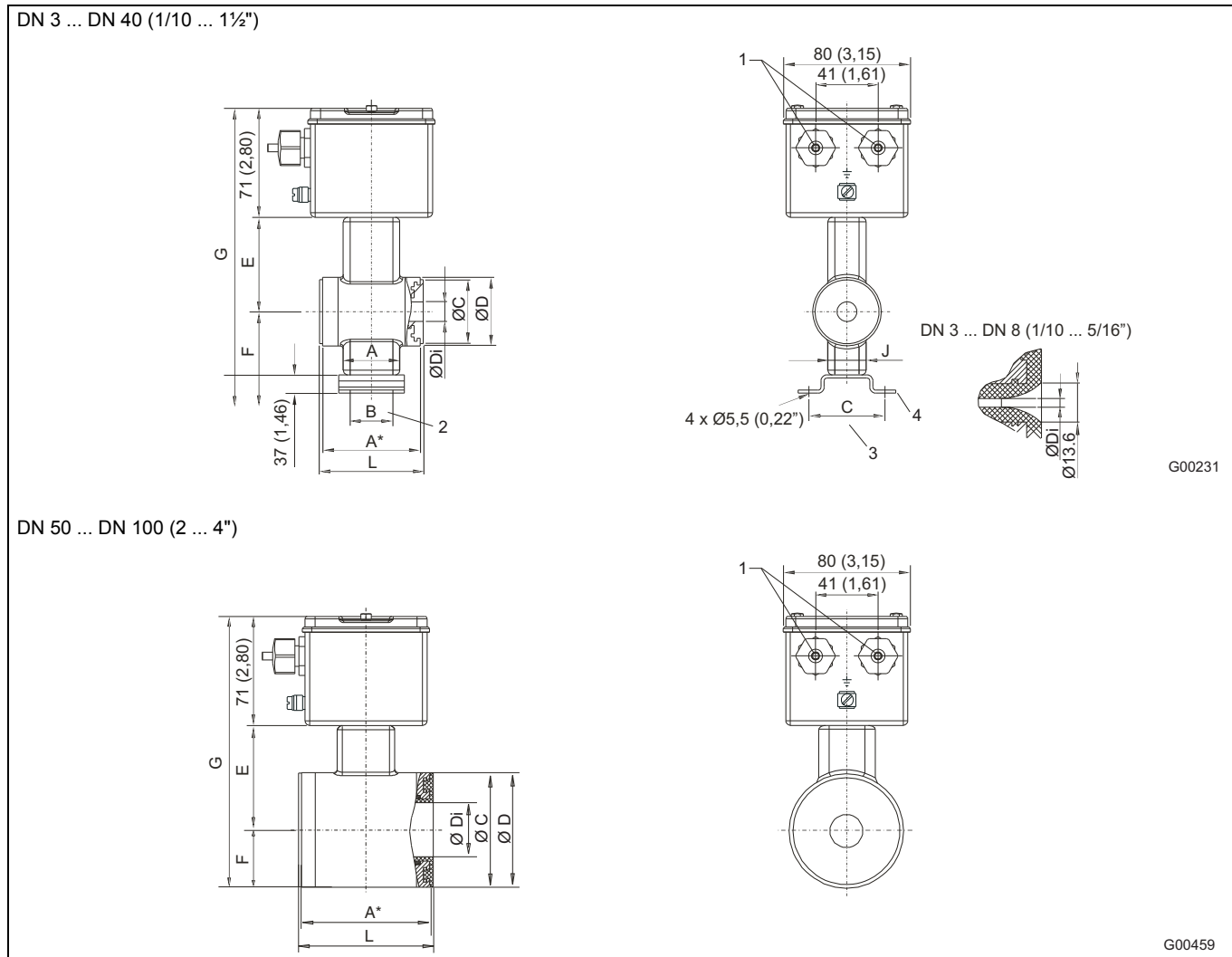

Fig. 33: Dimensions in mm (inch)

- 1 Cable gland Pg 13.5 or NPT
- 2 Pattern for axial holes
- 3 Hole pattern
- 4 Mounting bracket (optional)

DN (inch)	PN	Wafer type dimensions												Weight
		mm												approx. kg
		L ¹⁾	A*	A	B	C	ØC	ØDi	ØD	E	F	G	J	
3 (1/10) 4 (5/32) 6 (1/4) 8 (5/16) 10 (3/8) 15 (1/2)	10 ... 40 CL150 CL300 JIS	68	64	37	28	50	42	3 4 6 8 10 13	45	62	39	172	28	1,5
20 (3/4)		78	74	42	28	50	50	18	54	66	43	205	32	2,0
25 (1)		90	86	42	46	70	59	24	63	73	48	219	32	2,0
32 (1 1/4)		98	94	42	46	70	69	30	73	78	53	229	32	2,5
40 (1 1/2)		103	99	42	46	70	77	36	82	82	57	237	32	3,0
50 (2)		117	112	–	60	110	95	47	100	90	50	213	–	4,0
65 (2 1/2)	10 ... 16 CL150 JIS	103	99	–	60	110	111	62	116	105	58	235	–	4,5
80 (3)		103	99	–	60	110	128	74	133	114	67	252	–	6,5
100 (4)		133	129	–	60	110	155	96	160	128	80	279	–	8,5
DN (inch)	PN	inch												Approx. lb
		L ¹⁾	A*	A	B	C	ØC	ØDi	ØD	E	F	G	J	
3 (1/10) 4 (5/32) 6 (1/4) 8 (5/16) 10 (3/8) 15 (1/2)	10 ... 40 CL150 CL300 JIS	2.68	2.52	1.46	1.10	1.97	1.65	0.12 0.16 0.24 0.31 0.39 0.51	1.77	2.44	1.54	6.77	1.10	3.3
20 (3/4)		3.07	2.91	1.65	1.10	1.97	1.97	0.71	2.13	2.60	1.69	8.07	1.26	4.4
25 (1)		3.54	3.39	1.65	1.81	2.76	2.32	0.94	2.48	2.87	1.89	8.62	1.26	4.4
32 (1 1/4)		3.86	3.70	1.65	1.81	2.76	2.72	1.18	2.87	3.07	2.09	9.02	1.26	5.5
40 (1 1/2)		4.06	3.90	1.65	1.81	2.76	3.03	1.42	3.23	3.23	2.24	9.33	1.26	6.6
50 (2)		4.61	4.41	–	2.36	4.33	3.74	1.85	3.94	3.54	1.97	8.39	–	8.8
65 (2 1/2)	10 ... 16 CL150 JIS	4.06	3.90	–	2.36	4.33	4.37	2.44	4.57	4.13	2.28	9.25	–	9.9
80 (3)		4.06	3.90	–	2.36	4.33	5.04	2.91	5.24	4.49	2.64	9.92	–	14.3
100 (4)		5.24	5.08	–	2.36	4.33	6.10	3.78	6.30	5.04	3.15	10.98	–	18.7

1) Installation lengths with 2 ground plates L + 3 mm (0.12")

Mounting bracket (optional)

With mounting bracket, combined height + 37 mm (1.46") DN 3 ... DN 40 (1/10 ... 1½"), + 10.5 mm (0.41") DN 50 ... DN 100 (2 ... 4").

4.2.3 Model SE21_

Variable process connection

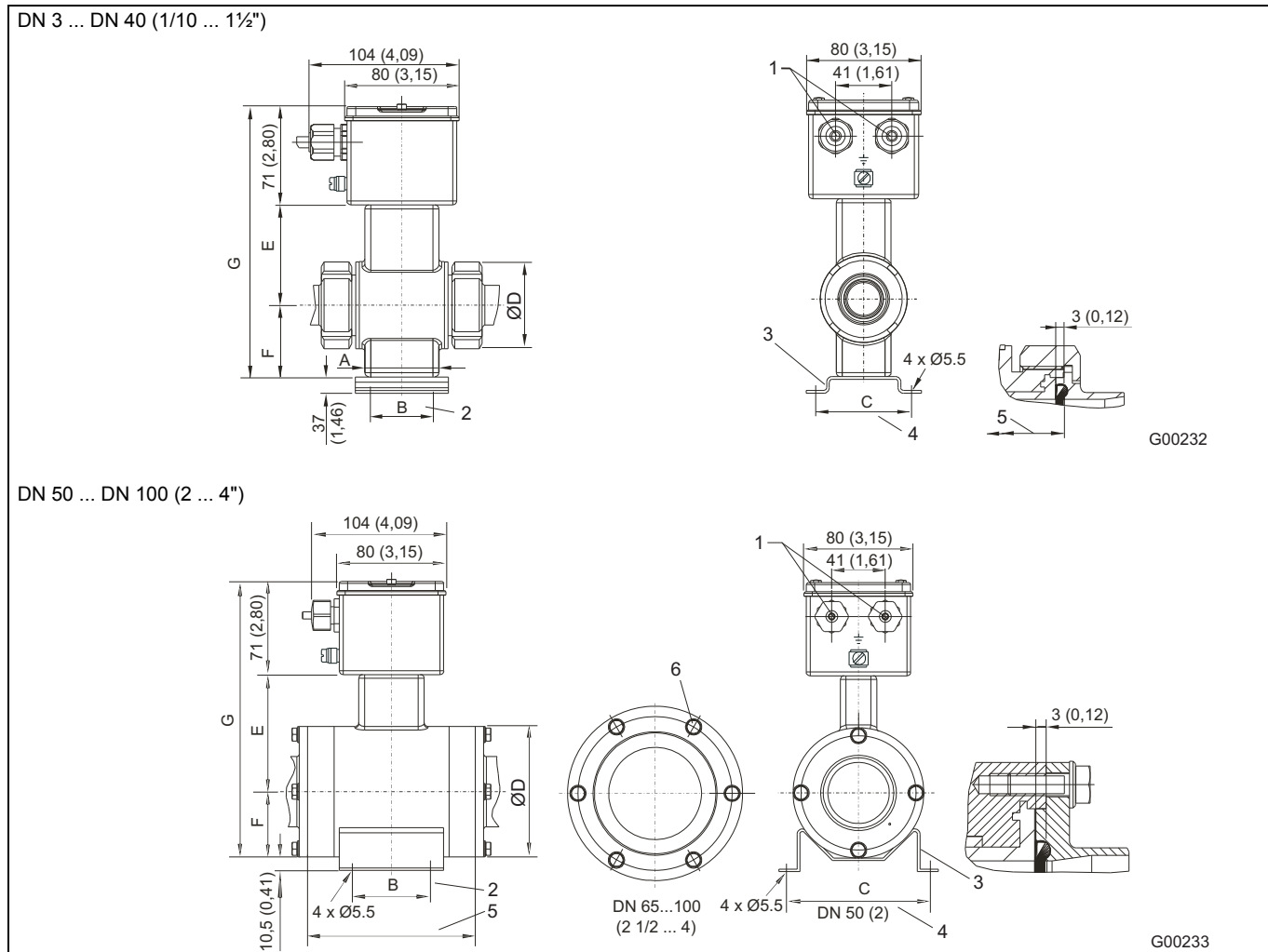

Fig. 34: Dimensions in mm (inch)

- 1 Cable gland Pg 13.5 or NPT
- 2 Pattern for axial holes
- 3 Mounting bracket (optional)
- 4 Hole pattern
- 5 L_{Pipe}
- 6 Number of holes N

DN (inch)	Variable process connection									Weight
	mm									appr. kg ¹⁾
	A	ØD	B	C	E	F	G	L _{pipe}	N	
3 ... 10 (1/10 ... 3/8)	37	44	28	50	62	39	172	85	–	1.5
15 (1/2)	37	44	28	50	62	39	172	85	–	1.5
20 (3/4)	42	63	28	50	66	43	180	90	–	2.0
25 (1)	42	63	46	70	73	48	192	105	–	2.0
32 (1 1/4)	42	78	46	70	78	53	202	120	–	2.5
40 (1 1/2)	42	78	46	70	82	57	210	125	–	3.0
50 (2)	–	100	60	110	90	50	211	128	8	4.0
65 (2 1/2)	–	116	60	110	105	58	234	114	10	4.5
80 (3)	–	133	60	110	114	67	252	114	6	6.5
100 (4)	–	160	60	110	128	80	279	114	6	9.0
DN (inch)	inch									appr. lb ¹⁾
	A	ØD	B	C	E	F	G	L _{pipe}	N	
3 ... 10 (1/10 ... 3/8)	1.46	1.73	1.10	1.97	2.44	1.54	6.77	3.35	–	3.3
15 (1/2)	1.46	1.73	1.10	1.97	2.44	1.54	6.77	3.35	–	3.3
20 (3/4)	1.65	2.48	1.10	1.97	2.60	1.69	7.09	3.54	–	4.4
25 (1)	1.65	2.48	1.81	2.76	2.87	1.89	7.56	4.13	–	4.4
32 (1 1/4)	1.65	3.07	1.81	2.76	3.07	2.09	7.95	4.72	–	5.5
40 (1 1/2)	1.65	3.07	1.81	2.76	3.23	2.24	8.27	4.92	–	6.6
50 (2)	–	3.94	2.36	4.33	3.54	1.97	8.31	5.04	0.31	8.8
65 (2 1/2)	–	4.57	2.36	4.33	4.13	2.28	9.21	4.49	0.39	9.9
80 (3)	–	5.24	2.36	4.33	4.49	2.64	9.92	4.49	0.24	14.3
100 (4)	–	6.30	2.36	4.33	5.04	3.15	10.98	4.49	0.24	19.8

¹⁾ For process connection weights see page 42

Mounting bracket (optional)

With mounting bracket, combined height +37 mm (1.46") DN 3 ... DN 40 (1/10 ... 1½"), +10.5 mm (0.41") DN 50 ... DN 100 (2 ... 4").

4.2.4 Adapter for variable process connections DN 3 ... DN 100 (1/10 ... 4")

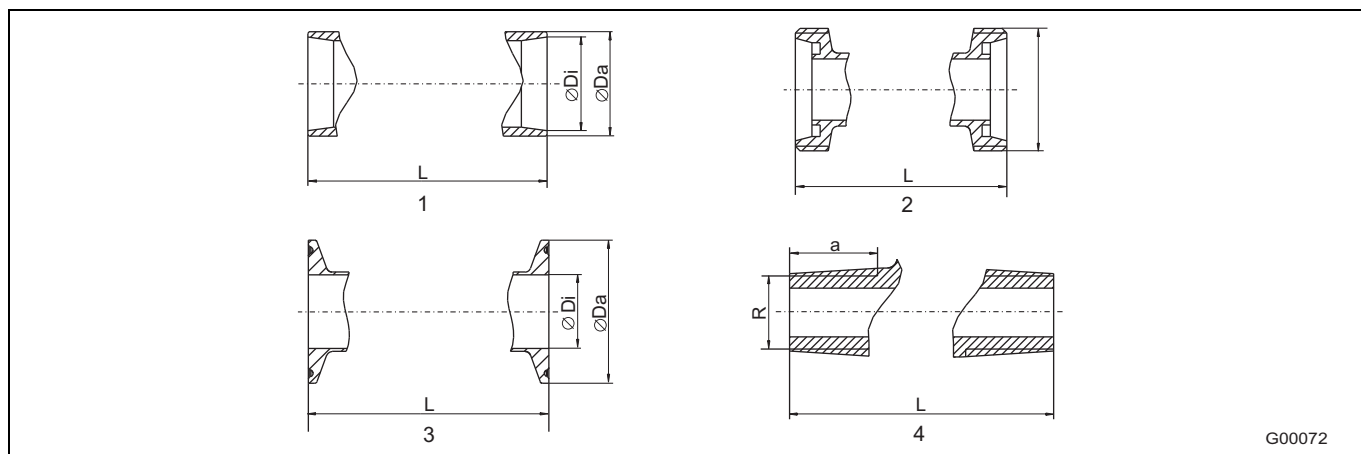

Fig. 35

- 1 Weld stubs
- 2 Threaded pipe connection DIN 11851
- 3 Tri-Clamp
- 4 External threads

DN (inch)	Weld stubs													Weight
	mm													kg
	ISO 2037		DIN 11850			SMS		DIN 2463		ISO 1127			L	
Ø Di	Ø Da	Ø Di	Ø Da	Series	Ø Di	Ø Da	Ø Di	Ø Da	Ø Di	Ø Da	Series	L		
3 ... 10 (1/10 ... 3/8)	10.0	12.0	10	13	2	-	-	10.3	13.5	10.3	13.5	1	127	0.4
15 (1/2)	15.2	17.2	16	19	2	-	-	18.1	21.3	18.1	21.3	1	127	0.4
20 (3/4)	19.3	21.3	20	23	2	-	-	23.7	26.9	23.7	26.9	1	132	0.7
25 (1)	22.6	25.0	26	29	2	22.6	25.0	25.0	28.0	23.7	26.9	1	149	0.7
32 (1 1/4)	31.3	33.7	32	34	1	-	-	32.0	35.0	30.5	33.7	1	166	1.0
40 (1 1/2)	35.6	38.0	38	41	2	35.6	38.0	36.8	40.0	39.0	42.2	1	171	1.0
50 (2)	48.6	51.0	50	53	2	48.6	51.0	49.0	52.0	47.8	51.0	2	173	1.0
65 (2 1/2)	60.3	63.5	66	70	2	60.3	63.5	66.0	70.0	66.0	70.0	2	165	1.4
80 (3)	72.9	76.1	81	85	2	72.9	76.1	81.0	85.0	72.9	76.1	1	169	2
100 (4)	97.6	101.6	100	104	2	100.0	104.0	100.0	104.0	97.6	101.6	2	199	3
DN (inch)	inch													lb
	ISO 2037		DIN 11850			SMS		DIN 2463		ISO 1127			L	
	Ø Di	Ø Da	Ø Di	Ø Da	Series	Ø Di	Ø Da	Ø Di	Ø Da	Ø Di	Ø Da	Series		
3 ... 10 (1/10 ... 3/8)	0.39	0.47	0.39	0.51	2	-	-	0.41	0.53	0.41	0.53	1	5.00	0.9
15 (1/2)	0.60	0.68	0.63	0.75	2	-	-	0.71	0.84	0.71	0.84	1	5.00	0.9
20 (3/4)	0.76	0.84	0.79	0.91	2	-	-	0.93	1.06	0.93	1.06	1	5.20	1.5
25 (1)	0.89	0.98	1.02	1.14	2	0.89	0.98	0.98	1.10	0.93	1.06	1	5.87	1.5
32 (1 1/4)	1.23	1.33	1.26	1.34	1	-	-	1.26	1.38	1.20	1.33	1	6.54	2.2
40 (1 1/2)	1.40	1.50	1.50	1.61	2	1.40	1.50	1.45	1.57	1.54	1.66	1	6.73	2.2
50 (2)	1.91	2.01	1.97	2.09	2	1.91	2.01	1.93	2.05	1.88	2.01	2	6.81	2.2
65 (2 1/2)	2.37	2.50	2.60	2.76	2	2.37	2.50	2.60	2.76	2.60	2.76	2	6.50	3.1
80 (3)	2.87	3.00	3.19	3.35	2	2.87	3.00	3.19	3.35	2.87	3.00	1	6.65	4.4
100 (4)	3.84	4.00	3.94	4.09	2	3.94	4.09	3.94	4.09	3.84	4.00	2	7.83	6.6

DN (inch)	Threaded pipe connection			Tri-Clamp									
	DIN 11851			DIN 32676					ASME BPE				
	mm			mm					mm				
	Rd. thd.	L	Weight /kg	Ø Di	Ø Da	Series	L	Weight /kg	Tri-Clamp	Ø Di	Ø Da	L	Weight kg
3 ... 10 (1/10 ... 3/8)	28 x 1/8"	169	0.5	10	34.0	3	163	0.5	1/2"	9.4	25.0	143	0.5
15 (1/2)	34 x 1/8"	169	0.5	16	34.0	3	163	0.5	3/4"	15.7	25.0	143	0.5
20 (3/4)	44 x 1/6"	180	0.9	20	34.0	3	168	0.7	1"	22.1	50.4	143	0.7
25 (1)	52 x 1/6"	207	0.9	26	50.5	3	192	0.8	1"	22.1	50.4	143	1.2
32 (1 1/4)	58 x 1/6"	230	1.4	32	50.5	3	209	1.5	-	-	-	-	-
40 (1 1/2)	65 x 1/6"	237	1.4	38	50.5	3	214	1.4	1 1/2"	34.8	50.4	277	1.8
50 (2)	78 x 1/6"	243	1.4	50	64.0	3	216	1.2	2"	47.5	63.9	277	1.8
65 (2 1/2)	96 x 1/6"	245	2.2	66	91.0	1	221	1.6	2 1/2"	60.2	77.4	277	2.0
80 (3)	110 x 1/4"	259	3.2	81	106.0	1	225	2.4	3"	72.9	90.9	337	3.6
100 (4)	130 x 1/4"	307	4.4	100	119.0	1	255	3.1	4"	97.4	118.9	337	4.1
DN (inch)	inch			inch					inch				
	Rd. thd.	L	Weight /lb	Ø Di	Ø Da	Series	L	Weight /lb	Tri-Clamp	Ø Di	Ø Da	L	Weight lb
3 ... 10 (1/10 ... 3/8)	28 x 1/8"	6.65	1.1	0.39	1.34	3	6.42	1.1	1/2"	0.37	0.98	5.63	1.1
15 (1/2)	34 x 1/8"	6.65	1.1	0.63	1.34	3	6.42	1.1	3/4"	0.62	0.98	5.63	1.1
20 (3/4)	44 x 1/6"	7.09	2.0	0.79	1.34	3	6.61	1.5	1"	0.87	1.98	5.63	1.5
25 (1)	52 x 1/6"	8.15	2.0	1.02	1.99	3	7.56	1.8	1"	0.87	1.98	5.63	2.6
32 (1 1/4)	58 x 1/6"	9.06	3.1	1.26	1.99	3	8.23	3.3	-	-	-	-	-
40 (1 1/2)	65 x 1/6"	9.33	3.1	1.50	1.99	3	8.43	3.1	1 1/2"	1.37	1.98	10.91	4.0
50 (2)	78 x 1/6"	9.57	3.1	1.97	2.52	3	8.50	2.6	2"	1.87	2.52	10.91	4.0
65 (2 1/2)	96 x 1/6"	9.65	4.9	2.60	3.58	1	8.70	3.5	2 1/2"	2.37	3.05	10.91	4.4
80 (3)	110 x 1/4"	10.20	7.1	3.19	4.17	1	8.86	5.3	3"	2.87	3.58	13.27	7.9
100 (4)	130 x 1/4"	12.09	9.7	3.94	4.69	1	10.04	6.8	4"	3.83	4.68	13.27	9.0

DN (inch)	External threads ISO 228 / DIN 2999, tapered			Weight kg
	mm			
	R	a	L	
3 ... 10 (1/10 ... 3/8)	3/8"	18	139	0.4
15 (1/2)	1/2"	18	139	0.4
20 (3/4)	3/4"	25	164	0.8
25 (1)	1"	25	179	0.8
DN (inch)	inch			lb
	R	a	L	
3 ... 10 (1/10 ... 3/8)	3/8"	0.71	5.47	0.88
15 (1/2)	1/2"	0.71	5.47	0.88
20 (3/4)	3/4"	0.98	6.46	1.76
25 (1)	1"	0.98	7.05	1.76

4.2.5 Model SE21B

1/8" sanitary connectors, DN 1 ... DN 2 (1/25 ... 3/32")

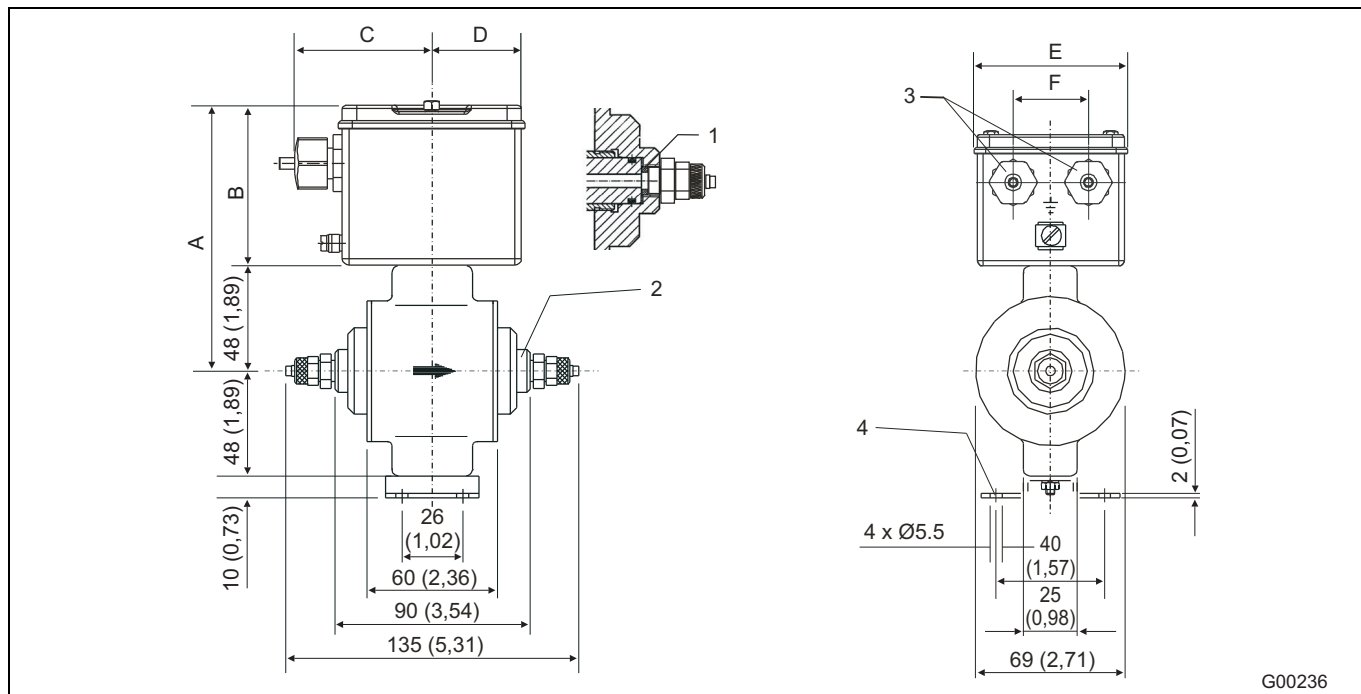

Fig. 36: Dimensions in mm (inch)

- 1 Gaskets
- 2 Connecting dimensions for gland G 1/8" internal thread
- 3 Cable gland Pg 13.5 or NPT
- 4 Mounting bracket, standard



Important

The flowmeter sensor is equipped as standard with grounding electrodes in the same material as the measuring electrodes. The flowmeter sensor can only be operated on S4 transmitters with software version B.30 or higher.

Preamplifier	A	B	C	D	E	F
Without / type A	119 (4.68)	71 (2.79)	64 (2.51)	40 (1.57)	80 (3.14)	41 (1.61)
Type B	104 (4.09)	56 (2.20)	163 (6.41)	71 (2.79)	142 (5.59)	70 (2.75)

Process Connection	DN	PN	Weight kg
1/8" sanitary connectors ¹⁾	1 ... 2 (1/25 ... 1/12")	10	1.5 (3.3 lb)

¹⁾ For hose 6 x 4 mm

4.3 Ordering information

Welded Flange, Liner Material PFA

		Main order number																											Add. order no.
Version number	1-6	7	8	9	10	11	12	13	14	15	16	17	18	19	20	21	22	23	24	25	26	27	28						
Electromagnetic Flowmeter FSM4000		SE21F-	X	X	X	X	X	X	X	X	X	X	X	X	X	X	X	X	X	X	X	X	X	X	X	XX			
Process Connection																										XX			
Welded flange DIN 2501 / ASME		F																											
Liner Material / Meter Size																													
PFA / DN 3 (1/10 in.)			P	0	3																								
PFA / DN 4 (5/32 in.)			P	0	4																								
PFA / DN 6 (1/4 in.)			P	0	6																								
PFA / DN 8 (5/16 in.)			P	0	8																								
PFA / DN 10 (3/8 in.)			P	1	0																								
PFA / DN 15 (1/2 in.)			P	1	5																								
PFA / DN 20 (3/4 in.)			P	2	0																								
PFA / DN 25 (1 in.)			P	2	5																								
PFA / DN 32 (1-1/4 in.)			P	3	2																								
PFA / DN 40 (1-1/2 in.)			P	4	0																								
PFA / DN 50 (2 in.)			P	5	0																								
PFA / DN 65 (2-1/2 in.)			P	6	5																								
PFA / DN 80 (3 in.)			P	8	0																								
PFA / DN 100 (4 in.)			P	1	H																								
Measuring Electrodes Material / Grounding Electrodes																													
Hastelloy C-4 (2.4610) / Without																													
Hastelloy B-3 (2.4600) / Without																													
AISI 316Ti SST (1.4571) / Without																													
Titanium / Without																													
Tantalum / Without																													
AISI 904L SST (1.4539) / Without						1)																							
Platinum-Iridium / Without																													
Hastelloy C-4 (2.4610) / With																													
Hastelloy B-3 (2.4600) / With																													
AISI 316Ti SST (1.4571) / With																													
Titanium / With																													
Tantalum / With																													
AISI 904L SST (1.4539) / With						1)																							
Platinum-Iridium / With																													
Pressure Rating																													
PN 16							2)																						
PN 40																													
ASME CL 150																													
ASME CL 300																													
Material of Process Connection																													
AISI 316Ti SST (1.4571)																													
Accessories																													
Without																													
Protection rings AISI 316Ti SST (1.4571)																													
Grounding ring AISI 316Ti SST (1.4571)																													
Temperature Range																													
Standard design (<= 130 °C [266 °F])																													
Certificates																													
PED Standard																													
Material certificate 3.1 acc. EN 10204 with pressure test AD2000																													
Pressure test AD2000																													
Inspection certificate 3.1 acc. EN 10204																													
Calibration Certificates																													
Standard																													
Fingerprint saved at factory																													

Continued on next page

- 1) For food and beverage applications
- 2) DN 65 (2-1/2 in.) / PN 16 with connection dimensions acc. EN 1092-1: Please order PN 40
- 3) Protection rings mounted on both sides and ground rings mounted on one side to flange. Material SST 1.4571 (316Ti)
- 4) Material certificate for meter tube and flanges
- 5) > DN 8 (1/12 in.)

		Main order number																												Add. order no.
Variantenstelle		1-6	7	8	9	10	11	12	13	14	15	16	17	18	19	20	21	22	23	24	25	26	27	28	XX					
Electromagnetic Flowmeter FSM4000		SE41F-	X	X	X	X	X	X	X	X	X	X	X	X	X	X	X	X	X	X	X	X	X	X	X	X	X	X	XX	
Type of Protection / Cable Entry																														
IP 67 / Thread for screw-type conduit fitting M20 x 1.5																												2		
IP 67 / Thread for screw-type conduit fitting NPT 1/2 in.																												4		
IP 68 / Thread for screw-type conduit fitting M20 x 1.5																												6) 7		
IP 68 / Cable connected and connection box potted																												8		
Design																														
Without pre-amplifier																												7) 1		
With pre-amplifier type A																												8) 2		
With pre-amplifier type B																												9) 4		
Name Plate Language / Type																														
German / Adhesive foil																												G		
English / Adhesive foil																												E		
French / Adhesive foil																												F		
German / Stainless steel																												J		
English / Stainless steel																												K		
French / Stainless steel																												L		
Design Level																														
(Specified by ABB)																												x		
Electrode Design																														
Standard																													1	
Conical head, AISI 904L SST (1.4539)																												10) 2		
Signal Cable Length																														
Without cable																													0 0 0	
5 m (16 ft)																													0 0 5	
10 m (33 ft)																													0 1 0	
20 m (66 ft)																													0 2 0	
30 m (99 ft)																													0 3 0	
40 m (131 ft)																													0 4 0	
50 m (164 ft)																													0 5 0	
60 m (195 ft)																													0 6 0	
70 m (230 ft)																													0 7 0	
80 m (260 ft)																													0 8 0	
90 m (295 ft)																													0 9 0	
100 m (325 ft)																													1 0 0	
125 m (410 ft)																													1 2 5	
150 m (490 ft)																													1 5 0	
175 m (570 ft)																													1 7 5	
200 m (660 ft)																													2 0 0	
Excitation Cable Length																														
Without cable																													0 0 0	
5 m (16 ft)																													0 0 5	
10 m (33 ft)																													0 1 0	
20 m (66 ft)																													0 2 0	
30 m (99 ft)																													0 3 0	
40 m (131 ft)																													0 4 0	
50 m (164 ft)																													0 5 0	
60 m (195 ft)																													0 6 0	
70 m (230 ft)																													0 7 0	
80 m (260 ft)																													0 8 0	
90 m (295 ft)																													0 9 0	
100 m (325 ft)																													1 0 0	
125 m (410 ft)																													1 2 5	
150 m (490 ft)																													1 5 0	
175 m (570 ft)																													1 7 5	
200 m (660 ft)																													2 0 0	

Continued on next page

- 6) Sealing compound (optional): D141B038U01
- 7) From DN 10 (3/8 in.) >= 20 µS/cm
- 8) Standard up to DN 8 (5/16 in.) >= 20 µS/cm, > DN 8 (5/16 in.) >= 5 µS/cm and lay length max. 200 m (660 ft)
- 9) Option: Up to DN 8 (5/16 in.) >= 5 µS/cm, > DN 8 (5/16 in.) >= 0.5 µS/cm and lay length max. 200 m (660 ft)
- 10) For application e.g. with high fat contents

		Main order number																										Add. order no.
Variantenstelle	1 – 6	7	8	9	10	11	12	13	14	15	16	17	18	19	20	21	22	23	24	25	26	27	28					
Electromagnetic Flowmeter FSM4000	SE41F-	X	X	X	X	X	X	X	X	X	X	X	X	X	X	X	X	X	X	X	X	X	X	X	X	XX		
Calibration																												
2 Points (Standard)																										VK		
3 Point Standard Calibration																										VC		
Witnessed Calibration, 5 Calibration Points																										11) VE		
5 Point Calibration acc. DKD																										11) VD		
Language of Documentation																												
German																										M1		
English																										M5		
Russian																										MB		
Language package Western Europe / Scandinavia (Languages DE, EN, DA, ES, FR, IT, NL, PT, FI, SV)																										ME		
Language package Eastern Europe (Languages DE, EL, CS, ET, LV, LT, HU, PL, SK, SL, RO, BG)																										MW		
Others																										MZ		
Other Usage Certifications																												
Russia, Metrological and GOST-R Certificate																										CG1		
Kazakhstan, Metrological and GOST-K Certificate																										CG2		
Ukraine, Metrological Certificate																										CG3		
Belarus, Metrological Certificate																										CG6		

11) Only available with FSM4000-S4 External Converter

Wafer Type / 1/8 in. Sanitary Connection / Variable Process Connections, Liner Material Torlon, PEEK, PFA

		Main order number																											Add. order no.
Version number	1-5	6	7	8	9	10	11	12	13	14	15	16	17	18	19	20	21	22	23	24	25	26	27	28	XX				
Electromagnetic Flowmeter		SE21-	X	X	X	X	X	X	X	X	X	X	X	X	X	X	X	X	X	X	X	X	X	X	X	XX			
FSM4000																									XX				
Process Connection																													
Wafer type		W																											
Weld stubs DIN 11850		R																											
Weld stubs DIN 2463		Q																											
Weld stubs ISO 1127		J																											
Weld stubs SMS		X																											
Without adapter	1)	V																											
Weld stubs ISO 2037		P																											
Pipe connection DIN 11851		S																											
Tri-Clamp DIN 32676		T																											
Tri-Clamp ASME BPE		K																											
Male thread ISO 228 / DIN 2999 conical		E																											
1/8 in. Pipe thread		B																											
Liner Material / Meter Size																													
PEEK / DN 1 (1/25 in.)			K	0	1																								
PEEK / DN 1,5 (1/17 in.)			K	1	S																								
PEEK / DN 2 (1/12 in.)			K	0	2																								
Torlon / DN 1 (1/25 in.)			N	0	1																								
Torlon / DN 1,5 (1/17 in.)			N	1	S																								
Torlon / DN 2 (1/12 in.)			N	0	2																								
PFA / DN 3 (1/10 in.)			P	0	3																								
PFA / DN 4 (5/32 in.)			P	0	4																								
PFA / DN 6 (1/4 in.)			P	0	6																								
PFA / DN 8 (5/16 in.)			P	0	8																								
PFA / DN 10 (3/8 in.)			P	1	0																								
PFA / DN 15 (1/2 in.)			P	1	5																								
PFA / DN 20 (3/4 in.)			P	2	0																								
PFA / DN 25 (1 in.)			P	2	5																								
PFA / DN 32 (1-1/4 in.)			P	3	2																								
PFA / DN 40 (1-1/2 in.)			P	4	0																								
PFA / DN 50 (2 in.)			P	5	0																								
PFA / DN 65 (2-1/2 in.)			P	6	5																								
PFA / DN 80 (3 in.)			P	8	0																								
PFA / DN 100 (4 in.)			P	1	H																								
Measuring Electrodes Material / Grounding Electrodes																													
Hastelloy C-4 (2.4610) / Without							H																						
Hastelloy B-3 (2.4600) / Without							B																						
AISI 316Ti SST (1.4571) / Without							S																						
Titanium / Without							M																						
Tantalum / Without							T																						
AISI 904L SST (1.4539) / Without					2)		F																						
Platinum-Iridium / Without							P																						
Hastelloy C-4 (2.4610) / With							O																						
Hastelloy B-3 (2.4600) / With							N																						
AISI 316Ti SST (1.4571) / With							E																						
Titanium / With							I																						
Tantalum / With							Q																						
AISI 904L SST (1.4539) / With					2)		R																						
Platinum-Iridium / With							G																						
Pressure Rating																													
PN 10							C																						
PN 16							D																						
PN 40							F																						
ASME CL 150							P																						
ASME CL 300							Q																						

Continued on next page

- 1) Spare sensor, for replacement only
- 2) For food and beverage applications

		Main order number																											Add. order no.
Version number		1-5	6	7	8	9	10	11	12	13	14	15	16	17	18	19	20	21	22	23	24	25	26	27	28	XX			
Electromagnetic Flowmeter FSM4000		SE21-	X	X	X	X	X	X	X	X	X	X	X	X	X	X	X	X	X	X	X	X	X	X	X	X	XX		
Material of Process Connection																													
Without																													0
AISI 316Ti SST (1.4571)																													3) 3
AISI 316L SST (1.4404)																													4
PVC																													4) 7
POM																													5) 8
Accessories																													
Without																													6) A
With fastening element																													7) C
Temperature Range																													
Standard design (<= 130 °C [266 °F]) (DN 1 ... DN 2: max. 120 °C [248 °F])																													S
Certificates																													
PED Standard																													A
Material certificate 3.1 acc. EN 10204 with pressure test AD2000																													8) D
Pressure test AD2000																													G
Inspection certificate 3.1 acc. EN 10204																													F
Calibration Certificates																													
Standard																													A
Fingerprint saved at factory																													9) F
Type of Protection / Cable Entry																													
IP 67 / Thread for screw-type conduit fitting M20 x 1.5																													2
IP 67 / Thread for screw-type conduit fitting NPT 1/2 in.																													4
IP 68 / Thread for screw-type conduit fitting M20 x 1.5																													10) 7
IP 68 / Cable connected and connection box potted																													8
Design																													
Without pre-amplifier																													11) 1
With pre-amplifier type A																													12) 2
With pre-amplifier type B																													13) 4
Name Plate Language / Type																													
German / Adhesive foil																													G
English / Adhesive foil																													E
French / Adhesive foil																													F
German / Stainless steel																													J
English / Stainless steel																													K
French / Stainless steel																													L
Design Level																													
(Specified by ABB)																													x
Electrode Design																													
Standard																													1
Conical head, AISI 904L SST (1.4539)																													14) 2

Continued on next page

- 3) Standard at 1/8 in. pipe thread and welded flange
- 4) DN 1 ... DN 2 (1/25 ... 1/12 in.) see Gasket
- 5) DN 1 ... DN 2 (1/25 ... 1/12 in.)
- 6) > DN 2 (1/12 in.)
- 7) No 3A conformity
- 8) Certificate for meter tube and adapter => DN 3 (1/10 in.)
- 9) > DN 8 (1/12 in.)
- 10) Sealing compound optional: D141B038U01
- 11) From DN 10 (3/8 in.) >= 20 µS/cm
- 12) Standard up to DN 8 (5/16 in.) >= 20 µS/cm, option > DN 8 (5/16 in.) >= 5 µS/cm and lay length max. 200 m (660 ft)
- 13) Option: Up to DN 8 (5/16 in.) >= 5 µS/cm, > DN 8 (5/16 in.) >= 0.5 µS/cm and lay length max. 200 m (660 ft)
- 14) For application e.g. with high fat contents

Main order number																						Add. order no.										
Version number	1	2	3	4	5	6	7	8	9	10	11	12	13	14	15	16	17	18	19	20	21	22	23	24	25	26	27	28	XX			
Electromagnetic Flowmeter FSM4000	SE21-	X	X	X	X	X	X	X	X	X	X	X	X	X	X	X	X	X	X	X	X	X	X	X	X	X	X	X	X	XX		
Gasket Material																																
Without																						A										
EPDM (with FDA certificate)																						E										
Silicone (with FDA certificate)																						S										
PTFE																						15) T										
Viton																						16) V										
Signal Cable Length																																
Without cable																						0	0	0								
5 m (16 ft)																						0	0	5								
10 m (33 ft)																						0	1	0								
20 m (66 ft)																						0	2	0								
30 m (99 ft)																						0	3	0								
40 m (131 ft)																						0	4	0								
50 m (164 ft)																						0	5	0								
60 m (195 ft)																						0	6	0								
70 m (230 ft)																						0	7	0								
80 m (260 ft)																						0	8	0								
90 m (295 ft)																						0	9	0								
100 m (325 ft)																						1	0	0								
125 m (410 ft)																						1	2	5								
150 m (490 ft)																						1	5	0								
175 m (570 ft)																						1	7	5								
200 m (660 ft)																						2	0	0								
Excitation Cable Length																																
Without cable																						0	0	0								
5 m (16 ft)																						0	0	5								
10 m (33 ft)																						0	1	0								
20 m (66 ft)																						0	2	0								
30 m (99 ft)																						0	3	0								
40 m (131 ft)																						0	4	0								
50 m (164 ft)																						0	5	0								
60 m (195 ft)																						0	6	0								
70 m (230 ft)																						0	7	0								
80 m (260 ft)																						0	8	0								
90 m (295 ft)																						0	9	0								
100 m (325 ft)																						1	0	0								
125 m (410 ft)																						1	2	5								
150 m (490 ft)																						1	5	0								
175 m (570 ft)																						1	7	5								
200 m (660 ft)																						2	0	0								

Continued on next page

- 15) Only DN 1 ... DN 2 (1/25 ... 1/12 in.)
- 16) Only DN 1 ... DN 2 (1/25 ... 1/12 in.) and PVC process connection

		Main order number																				Add. order no.			
Version number	1 – 5	6	7	8	9	10	11	12	13	14	15	16	17	18	19	20	21	22	23	24	25	26	27	28	
Electromagnetic Flowmeter FSM4000	SE21-	X	X	X	X	X	X	X	X	X	X	X	X	X	X	X	X	X	X	X	X	X	X	X	XX
Calibration																									
2 Points (Standard)																								VK	
3 Point Standard Calibration																								VC	
Witnessed Calibration, 5 Calibration Points																								17) VE	
5 Point Calibration acc. DKD																								17) VD	
Language of Documentation																									
German																								M1	
English																								M5	
Russian																								MB	
Language package Western Europe / Scandinavia (Languages DE, EN, DA, ES, FR, IT, NL, PT, FI, SV)																								ME	
Language package Eastern Europe (Languages DE, EL, CS, ET, LV, LT, HU, PL, SK, SL, RO, BG)																								MW	
Others																								MZ	
Other Usage Certifications																									
Russia, Metrological and GOST-R Certificate																								CG1	
Kazakhstan, Metrological and GOST-K Certificate																								CG3	
Ukraine, Metrological Certificate																								CG3	
Belarus, Metrological Certificate																								CG6	

17) Only available with FSM4000-S4 External Converter

5 Mounting accessories

Wafer type accessories

The following accessories are available based on meter size and pressure rating: Bolts, nuts, lockwashers. Gaskets are not included in the accessories. For order information, see page 53 .

Weld connections

For flowmeters with welded connections, welding adapters are available. For order information, see page 53 .

5.1 Ordering information Wafer type Accessories (Table H)

Wafer type Accessories

Description	Nominal size	Nominal pressure rating	Order number
FX / FSM Wafer type Accessories	DN 3 ... DN 10 (1/10 ... 3/8 in.)	PN 10 ... PN 40	D614L265U03
		ASME CL 150	D614L265U03
		ASME CL 300	D614L265U04
	DN 15 (1/2 in.)	PN 10 ... PN 40	D614L265U03
		ASME CL 150	D614L266U05
		ASME CL 300	D614L266U06
	DN 20 (3/4 in.)	PN 10 ... PN 40	D614L267U04
		ASME CL 150	D614L267U05
		ASME CL 300	D614L267U06
	DN 25 (1 in.)	PN 10 ... PN 40	D614L268U04
		ASME CL 150	D614L268U05
		ASME CL 300	D614L268U06
DN 32 (1-1/4 in.)	PN 10 ... PN 40	D614L269U04	
	ASME CL 150	D614L269U05	
	ASME CL 300	D614L269U06	
DN 40 (1-1/2 in.)	PN 10 ... PN 40	D614L270U04	
	ASME CL 150	D614L270U05	
	ASME CL 300	D614L270U06	
DN 50 (2 in.)	PN 10 ... PN 40	D614L296U04	
	ASME CL 150	D614L296U05	
	ASME CL 300	D614L296U06	
DN 65 (2-1/2 in.)	PN 10 ... PN 16	D614L297U08	
	PN 25 ... PN 40	D614L297U09	
	ASME CL 150	D614L297U10	
	ASME CL 300	D614L297U11	
DN 80 (3 in.)	PN 10 ... PN 40	D614L298U08	
	ASME CL 150	D614L298U09	
	ASME CL 300	D614L298U10	
DN 100 (4 in.)	PN 10 ... PN 16	D614L299U07	
	PN 25 ... PN 40	D614L299U08	
	ASME CL 150	D614L299U09	

Welding adapter

Material	Nominal size	Order number
Stainless steel AISI 304 (1.4301)	DN 3 ... DN 10 (1/10 ... 3/8 in.)	D413C470U01
		D413C471U01
		D413C472U01
	DN 25 (1 in.)	D413C473U01
		D413C474U01
		D413C475U01
	DN 40 (1-1/2 in.)	D413C475U01
		D413C475U01
		D413C488U03
	DN 65 (2-1/2 in.)	D413C461U09
		D413C496U03
		D413C498U03

The adapter is a tool for sensors that feature weld stubs as the process connection type. It enables these weld stubs to be welded into the pipeline in a coplanar manner.

6 Transmitter

6.1 Specifications



Fig. 37: Transmitter FSM4000-S4

Measuring range	Any flow range whose 100% value corresponds to a flow velocity between 0.5 m/s and 10 m/s can be selected.	
Minimum conductivity	$\geq 20 \mu\text{S/cm}$ standard	DN 10 ... 1000 (3/8 ... 40")
	$\geq 20 \mu\text{S/cm}$ with preamplifier	DN 1 ... 8 (1/25 ... 5/16")
	$\geq 5 \mu\text{S/cm}$ with preamplifier	DN 1 ... 1000 (1/25 ... 40")
	$\geq 0.5 \mu\text{S/cm}$ with preamplifier	DN 10 ... 1000 (3/8 ... 40")
Repeatability (measurement period = 100 s)	DN 1 ... 2 (1/25 ... 1/12"): $\leq \pm (0.3 \text{ \% of measured value} + 0.04 \text{ \% of } Q_{\text{maxDN}})$	
	DN 3 ... 1000 (1/10 ... 40"): $\leq \pm (0.1 \text{ \% of measured value} + 0.01 \text{ \% of } Q_{\text{maxDN}})$	
Response time	$1\tau = 70 \text{ ms}$ (0 ... 66 %) "Fast" mode $1\tau = 200 \text{ ms}$ (0 ... 66 %) "Standard" mode/piston pump	
Supply power	U = 100 ... 230 V, 50 / 60 Hz U _{rat} = 85 ... 253 V, 50 / 60 Hz 50/60 Hz $\pm 6\%$ 20.4 ... 26.4 V AC, 20.4 ... 31.2 V DC, ripple $\leq 5 \%$	
Power consumption	S $\leq 45 \text{ VA}$ (flowmeter sensor including transmitter)	
Ambient temperature	-20 ... 60 °C (-4 ... 140 °F)	
Storage temperature	-20 ... 80 °C (-4 ... 176 °F)	

Relative humidity

Acc. to IEC 60068-2-30 classification of environmental conditions, natural factors, temperature and air humidity. No effect under the following conditions: Temperature in range from 25 ... 55 °C (77 ... 131 °F) and a relative humidity of 94 ... 97%.

Vibration

Acc. to IEC 60068-2-6 (03/95), grouping of devices according to table C2 for general industry applications. No additional effect on the following levels of vibration. Frequency: 10 ... 55 Hz; amplitude max. 0.15 mm.

Degree of protection acc. to EN 60529

IP 67 for field-mount housing and NEMA 4X

Design

Field-mount housing made of cast aluminum per DIN 1725, painted. Paint coat thickness 80 μm . Lower section (RAL 7012), upper section (RAL 9002). See dimensions on page 65. Weight, approx. 3.3 kg.

Electrical connections

Cable entry M20 x 1.5, NPT, PF with adapter (upon request), screw terminals

Damping (1τ)

Configurable for 0.07 ... 20 s.

Low flow cutoff

Configurable for 0 ... 10% of end value range

Signal cable

Max. cable length between flowmeter sensor and transmitter is: 50 m for the standard design and versions with automatic zero return, from DN 10 (3/8") and from 20 $\mu\text{S/cm}$. 200 m for designs with preamplifier. A 5 m signal cable is included with each flowmeter. If a longer cable is required, see the order information for the flowmeter sensor on page 22 , 45.

Magnet coil supply cable

Is required to connect the flowmeter sensor to the transmitter. For EMC reasons, the 2-wire cable is shielded. A 5 m cable is included with each flowmeter. If a longer cable is required, see the order information for the flowmeter sensor on page 22 , 45.

Forward/reverse flow metering

Flow direction is indicated by direction arrows in the display and over the contact for external signaling. The contact output can also transmit this information.

Display

4-line, illuminated graphic display. To improve readability, the flow information can be displayed on two lines with larger characters. This allows the individual flowrate and output values to be displayed. Non-switching dot-matrix display with max. 4 x 16 characters. A plaintext diagnostic display opens automatically when the system detects an error. An alarm condition can also be signaled via contact output.

Data backup

Via FRAM (ferroelectric non-volatile random access memory) all data is stored for a period of 10 years (even without supply power) at shut-off or during a power outage. Additional security is provided by a serial FRAM installed in the transmitter and on the external connection board in which the parameter settings and process information are stored. This makes it easy to replace a transmitter – without reconfiguration – by simply uploading the stored data from the external FRAM to the new transmitter.

Flow totalization

The flow is totalized in engineering units. The limits for the pulse factor are configurable and depend on the measuring range (Q_{max}) as well as the totalizer units selected. The limits are a min. (0.00016 Hz) and max. pulse frequency (5 KHz). Totalizer values for the forward and reverse flow directions can be displayed simultaneously by selecting the "Display" menu item.

Parameter adjustment

The display supports several languages (German, English, French, Finnish, Swedish, Italian, Spanish, Dutch or Turkish), and information can be entered using the three keys in the dialog or via a communication interface with PC, HART protocol, PROFIBUS or FOUNDATION Fieldbus. The magnet stick can also be used to configure the flowmeter with the front door closed. Position the magnet stick over the magnet icons on the display cover.

Alarm signals

A max-min alarm can be used with the transmitter. The alarm limits can be set between 0 ... 103% of the flow range. When the flowrate is outside the alarm limits, an error message is displayed in the upper line and a contact is triggered. The contact output can also transmit this information.

Wiring error

Monitoring of magnet coil or electrode circuits for short circuits or wire breaks.

Upgrades

The transmitter with all its functions can also be used with older model electromagnetic flowmeters. The appropriate model number must be selected during parameter setting of the transmitter. It is also possible to use the transmitter with model 10D1422 flowmeters. A special FRAM (Cs = 100 %, Cz = 0 %) is required when updating an older model (see order information for transmitter) and applies for meter sizes DN 3 ... DN 1000 (1/10 ... 40") in low voltage design only.

Isolation of input/output

The current output, pulse output, contact input and contact output are electrically isolated from the input circuit and from each other.

Extended diagnostic functions

Recorded parameters/fingerprints

Cyclical (10 s ... 7 days) or manual acquisition of parameters. The data records are stored in the transmitter FRAM (with time stamp / operating hours counter). A maximum of 10 records can be stored. When the eleventh record is stored, the oldest data record is overwritten automatically.

Magnet coil circuit	AC voltage
	AC
	DC resistance (primary value for temperature)
	Temperature
	Insulation resistance (ground)
	DAC value (primary value for coil current)
Electrode circuit	Magnetic linearity
	Electrode voltage E1 (primary value for electrode balance)
	Electrode voltage E2 (primary value for electrode balance)
	Electrode balance
	Quality (signal-to-noise ratio)

The parameters can be checked for min.-max. errors. If the value is above or below the specified limit, a diagnostic error or warning, depending on the configuration, is triggered. The fingerprint database integrated in the transmitter allows you to compare the values at the time of factory calibration or commissioning with the currently recorded values.

Users can store up to three different fingerprint data records (commissioning, product1, product2) in the fingerprint database. The default fingerprint (optional) cannot be overwritten.

Detectable error states

Monitoring of ...	Detection of ...
Coil current / coil voltage / DAC value	Changes in the driver or coil circuit.
Coil resistance	Changes in coil circuit, e.g., fine short.
Coil temperature	Risk of overheating due to fluid.
Coil insulation resistance	Problems with the coil insulation. Can be caused, e.g., by dampness in the flowmeter sensor or in the connection box.
Linearity of magnetic circuit	External magn. field interference on the EMF, resulting in loss of accuracy.
Signal quality (signal-to-noise ratio)	Changes in fluid, e.g., gas bubbles, increased / reduced amount of solids.
Electrode balance	Distorted flow profile, e.g., due to improper installation. Detect interference in electrode circuit, e.g., failure of electrode due to insulating coating or a collapsed liner (vacuum shock).

Backward compatibility

The transmitter is suitable for connecting to flowmeter sensors over 20 years old. Occasionally, an adapter board may be required (for details, see the FSM4000 operating instructions).

The following flowmeter sensors are supported:
DS21, DS21F, DS41F, 10DS3111 (A-E), 10D1425, 10D1422, 10D1462, 10D1472

6.2 Inputs/outputs

DC output (terminals 31, 32)

The following functions can be selected in the software:

- 0 ... 20 mA load $\leq 560 \Omega$
- 4 ... 20 mA load $\leq 560 \Omega$
- 0 ... 10 mA load $\leq 1120 \Omega$
- 2 ... 10 mA load $\leq 1120 \Omega$

Contact output (terminals 41, 42)

The following functions can be selected in the software:

- Forward/reverse flow direction signal
- Flowrate alarm (max. or min.)
- General alarm
- Empty pipe

The contact output can be configured as normally open or normally closed.

Optocoupler

"closed" $0 \text{ V} \leq U_{\text{CEL}} \leq 2 \text{ V}$, $2 \text{ mA} \leq I_{\text{CEL}} \leq 220 \text{ mA}$

"open" $16 \text{ V} \leq U_{\text{CEH}} \leq 30 \text{ V}$, $0 \text{ mA} \leq I_{\text{CEH}} \leq 2 \text{ mA}$

Scaled pulse output (terminals 51, 52)

Maximum totalizer frequency 5 kHz. Pulse factor per engineering unit from 0.001 ... 1000 / unit selectable in the software. The pulse width is configurable from 0.100 ... The version (active, passive) can be changed via jumpers.

Active

Voltage pulse 24 V rectangular

- Load $\geq 150 \Omega$
Pulse width $\leq 50 \text{ ms}$, max. pulse frequency $\leq 3 \text{ Hz}$,
- Load $\geq 500 \Omega$
Pulse width $\geq 0.1 \text{ ms}$, max. pulse frequency: 5 kHz.

Passive

Optocoupler

"closed": $0 \text{ V} \leq U_{\text{CEL}} \leq 2 \text{ V}$, $2 \text{ mA} \leq I_{\text{CEL}} \leq 220 \text{ mA}$

"open": $16 \text{ V} \leq U_{\text{CEH}} \leq 30 \text{ V}$, $0 \text{ mA} \leq I_{\text{CEH}} \leq 2 \text{ mA}$

Contact input (terminals 81/82)

Passive based on normally open contact (closed). The following functions can be selected in the software:

- External output signal switch-off
When the meter tube empties the output signals can be turned off. DC output, e.g., 0 mA or 2/4 mA, depending on current output configuration.
- External totalizer reset
For totalizer overflows displayed internally and pulse counters for both flow directions.
- External system zero position
Starts the external zero adjustment. To run a zero adjustment, the metering tube must be full and flowrate must be zero. The adjustment lasts approx. 1 minute.
- Design passive (optocoupler)
"ON": $16 \text{ V} \leq U_{\text{KL}} \leq 30 \text{ V}$
"OFF" $0 \text{ V} \leq U_{\text{KL}} \leq 2 \text{ V}$
Ri: 2 k Ω

6.3 Digital communication

The transmitter has the following options for digital communication:

6.3.1 HART protocol

The unit is registered with the HART Communication Foundation.

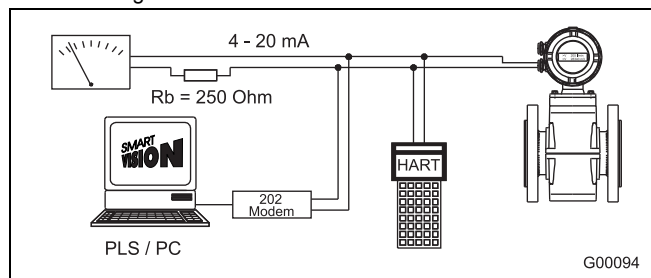

Fig. 38

HART protocol	
Configuration	Directly on the device Software DAT200 Asset Vision Basic (+ HART-DTM)
Transmission	FSK modulation on current output 4 ... 20 mA acc. to Bell 202 standard
Max. signal amplitude	1.2 mA _{SS}
Current output load	Min. 250 Ω , max. = 560 Ω
Cable	AWG 24 twisted
Max. cable length	1500 m
Baud rate	1200 baud
Display	Log. 1: 1200 Hz Log. 0: 2200 Hz

For additional information, see the separate interface description.

System integration

In conjunction with the DTM (Device Type Manager) available for the device (software version B.10 and higher), communication (configuration, parameterization) can occur with the corresponding framework applications according to FDT 1.21 (DAT200 Asset Vision Basic).

Other tool/system integrations (e.g., Emerson AMS/Siemens S7) are available upon request.

A free of charge version of the DAT200 Asset Vision Basic framework application for HART® or PROFIBUS is available upon request.

The required DTMs are contained on the DAT200 Asset Vision Basic DVD or in the DTM Library.

They can also be downloaded from www.abb.com/flow.

6.3.2 PROFIBUS PA protocol

The interface conforms to Profile 3.0 (PROFIBUS standard, EN 50170, DIN 19245 [PRO91]).

PROFIBUS PA ID no.:	0x078C
Alternative standard ID no.:	0x9700 or 0x9740
Configuration	Directly on the device Software DAT200 Asset Vision Basic (+ PROFIBUS PA-DTM)
Transmission signal	Acc. to IEC 61158-2
Cable	Shielded, twisted cable (acc. to IEC 61158-2, types A or B are preferred)

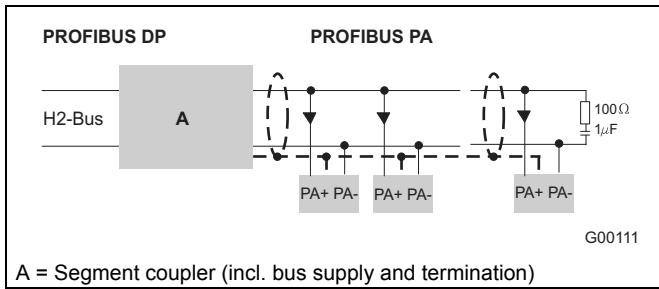

Fig. 39: Example for PROFIBUS PA interface connection

Bus topology

- Tree and / or line structure
- Bus termination: passive at both ends of the main bus line (RC element R = 100 Ω, C = 1 μF)

Voltage / current consumption

- Average current consumption: 10 mA
- In the event of an error, the integrated FDE function (=Fault Disconnection Electronic) integrated in the device is ensures that the current consumption can rise to a maximum of 13 mA.
- The upper current limit is restricted electronically.
- The voltage on the bus line must lie in the range of 9 ... 32 V DC.

Bus address

In the case of devices with a PROFIBUS PA interface, check the bus address prior to commissioning. If no specifications exist to the contrary, the address is set to 126. During commissioning, the address must be set to a valid value in the range 0 ... 125.

System integration

Use of PROFIBUS PA profile B, B3.0 ensures interoperability and interchangeability of units. Interoperability means that devices from different manufacturers can be physically connected to a bus and are communication-ready.

The devices can be interchanged without having to reconfigure the process control system.

To support interchangeability, three different GSD files (equipment master data) are provided, which can be integrated in the system.

For additional information, see the separate interface description.

The manufacturer-specific GSD file ABB_078C can be downloaded from <http://www.abb.com/flow>.

The standard GSD files PA1397xx.gsd can be downloaded from <http://www.profibus.com>.

6.3.3 FOUNDATION Fieldbus (FF)

FF interface	Compliant with FF standard 890/891 and FF 902/90
Interoperability test campaign no.	IT 027200 (ITK 4.6)
Manufacturer ID	0x000320
Device ID	0x0017
Configuration	<ul style="list-style-type: none"> • Directly on the device • Via services integrated in the system • National configurator
Transmission signal	Acc. to IEC 61158-2

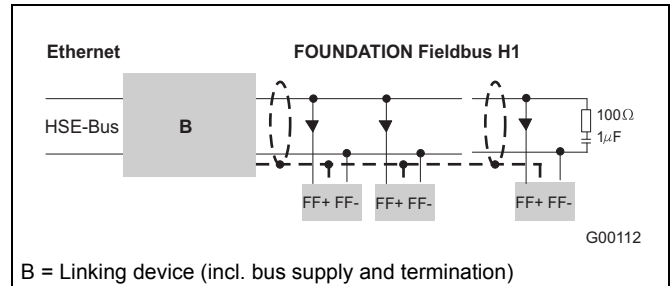

Fig. 40: Example for FOUNDATION Fieldbus interface connection

Bus topology

- Tree and / or line structure
- Bus termination: passive at both ends of the main bus line (RC element R = 100 Ω, C = 1 μF)

Voltage / current consumption

- Average current consumption: 10 mA
- In the event of an error, the integrated FDE function (=Fault Disconnection Electronic) integrated in the device is ensures that the current consumption can rise to a maximum of 13 mA.
- Upper current limit: electronically restricted.
- The voltage on the bus line must lie in the range of 9 ... 32 V DC.

Bus address

The bus address is automatically assigned or can be set in the system manually.

Addresses are detected using a unique combination of manufacturer ID, device ID, and device serial number.

System integration

The following are required:

- DD (Device Description) file, which includes the device description.
- The CFF (Common File Format) file is required for engineering the segment. Engineering can be performed online or offline.

For additional information, see the separate interface description.

The files required for operation can be downloaded from <http://www.fieldbus.org>.

6.4 Electrical connections

Standard DN 10 ... DN 1000 (3/8 ... 40")

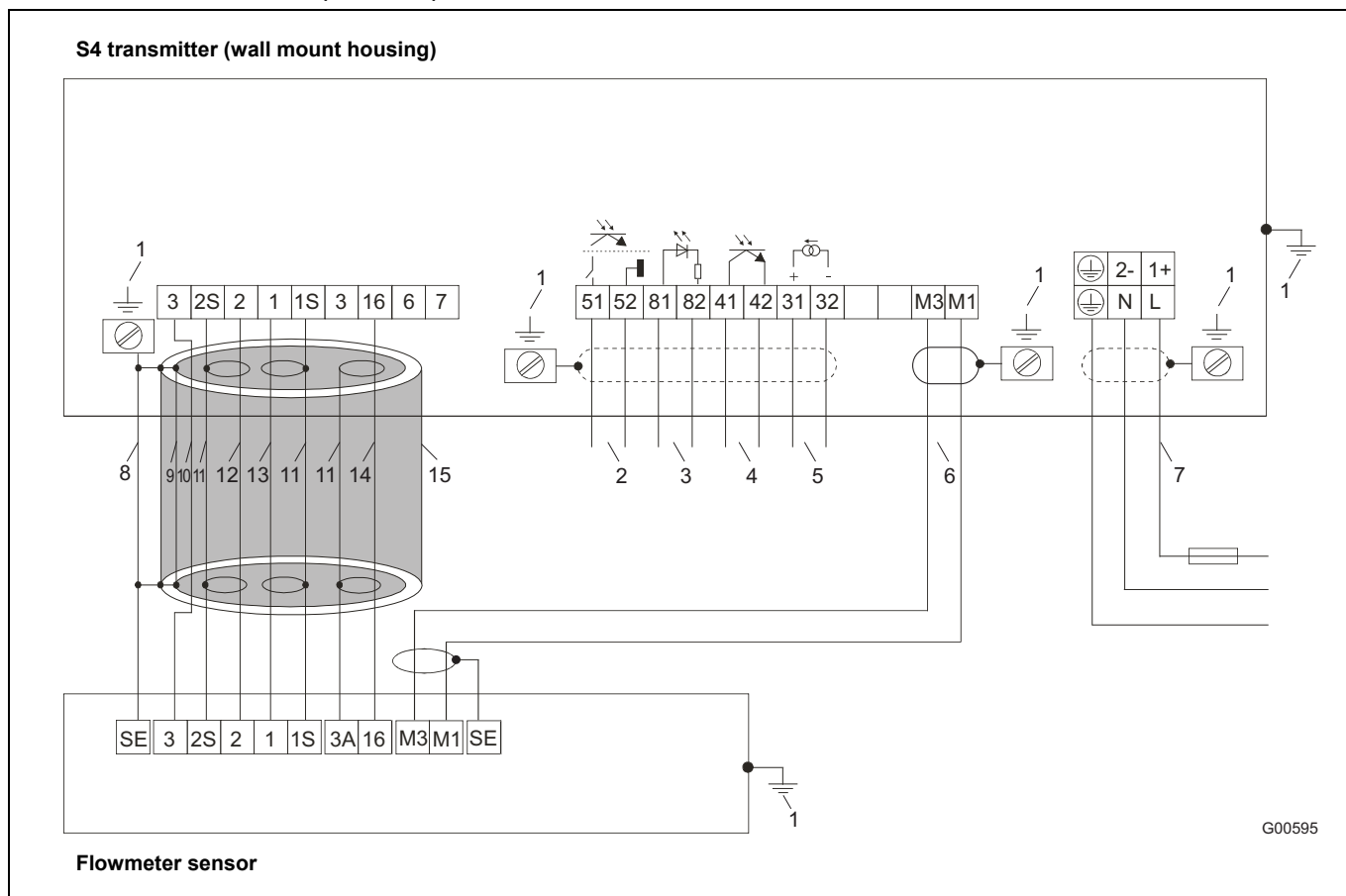

Fig. 41: Connection diagram: Flowmeter sensor standard DN 10 ... DN 1000 (3/8 ... 40")

- | | |
|---|---|
| 1 Functional ground (busbar) | 8 Steel shielding |
| 2 Pulse output ¹⁾ | 9 Aluminum foil |
| 3 Contact input ¹⁾ | 10 Yellow |
| 4 Contact output ¹⁾ | 11 Shield |
| 5 Current output ¹⁾ | 12 Blue |
| 6 Magnet coil cable: | 13 Red |
| shielded 2 x 1 mm ² CE Typ 227 TEC 74 | 14 White |
| ABB order no. D173D147U01, 10 m included in shipment, | 15 Shielded signal cable: ABB order no. D173D025U01, 10 m |
| standard | included in shipment |
| 7 Supply power | |
| Low voltage: 100 ... 230 V AC, terminals L, N, ⊕ | |
| Low voltage: 20.4 ... 26.4 V AC; | |
| 20.4 ... 31.2 V DC | |
| Terminals 1+, 2-, ⊕ | |
| Frequency: 47 Hz ≤ f ≤ 53 Hz; 50 Hz supply power | |
| 56 Hz ≤ f ≤ 64 Hz; 60 Hz supply power | |

1) See the section "Connection examples for peripherals" in the operating instructions and/or on the data sheet

Comment:

We recommend that shielded output cables be used with the shields connected to the functional ground at one end.

with preamplifier DN 1 ... DN 1000 (1/25 ... 40")

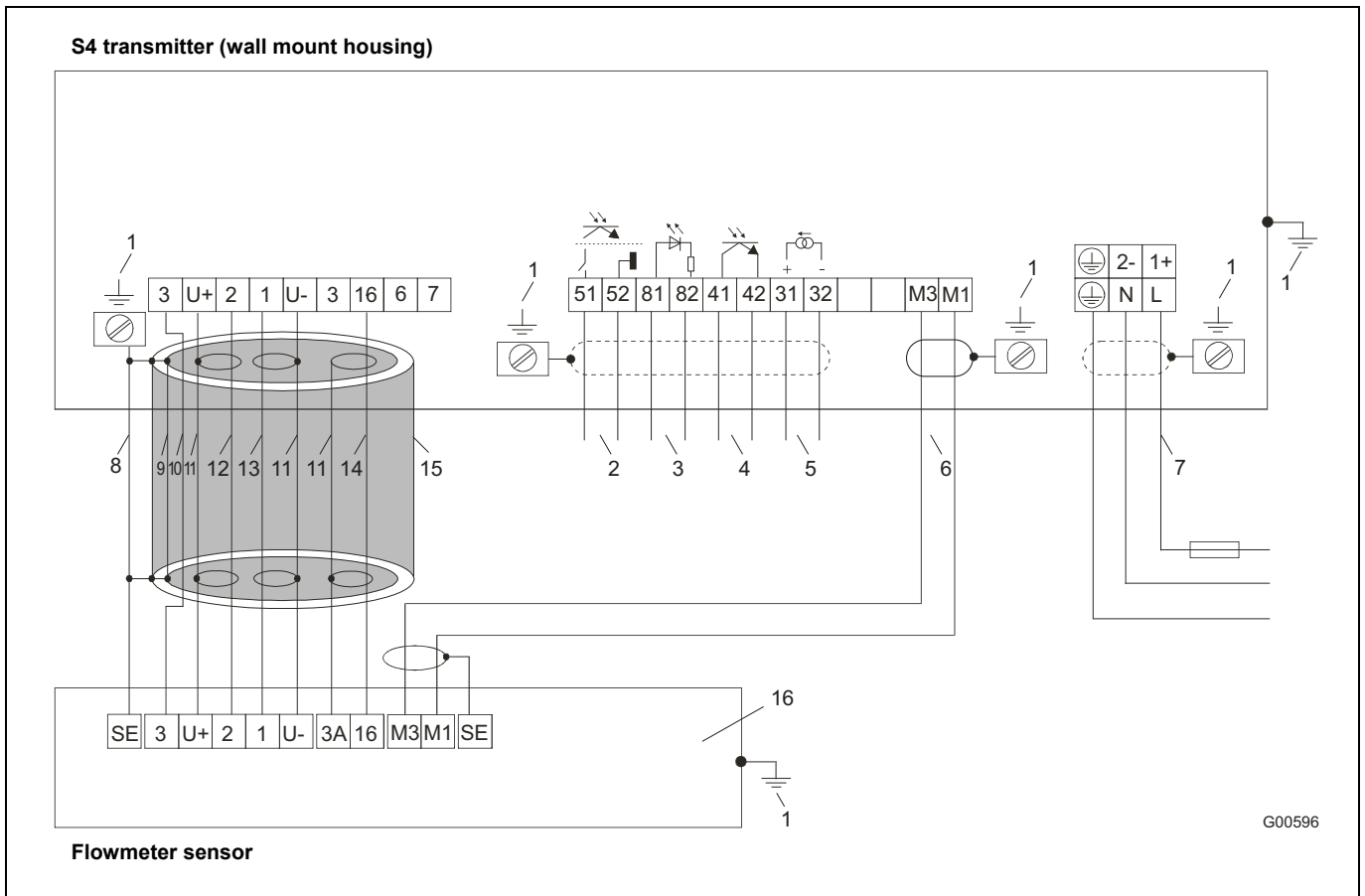

Fig. 42: Connection diagram: Flowmeter sensor with preamplifier DN 1 ... DN 1000 (1/25 ... 40"), transmitter field-mount housing

- 1 Functional ground (busbar)
- 2 Pulse output¹⁾
- 3 Contact input¹⁾
- 4 Contact output¹⁾
- 5 Current output¹⁾
- 6 Magnet coil cable:
shielded 2 x 1 mm² CE Typ 227 TEC 74
ABB order no. D173D147U01, 10 m included in shipment,
standard
- 7 Supply power
Low voltage: 100 ... 230 V AC, terminals L, N, ⊕
Low voltage: 20.4 ... 26.4 V AC;
20.4 ... 31.2 V DC
Terminals 1+, 2-, ⊕
Frequency: 47 Hz ≤ f ≤ 53 Hz; 50 Hz supply power
56 Hz ≤ f ≤ 64 Hz; 60 Hz supply power
- 8 Steel shielding
- 9 Aluminum foil
- 10 Yellow
- 11 Shield
- 12 Blue
- 13 Red
- 14 White
- 15 Shielded signal cable: ABB order no. D173D025U01,
10 m, included in shipment
- 16 With preamplifier (always with DN 1 ... DN 8 [1/25 ... 5/16"])

1) See the section "Connection examples for peripherals" in the operating instructions and/or on the data sheet

Comment:

We recommend that shielded output cables be used with the shields connected to the functional ground at one end.



Important

If the flowmeter sensor is equipped with a preamplifier for low conductivity or in nominal diameter DN 1 ... DN 8 (1/25 ... 5/16"), the shieldings of the signal wires must be connected to terminals U+ and U- on both the flowmeter sensor and the transmitter.

**Retrofitting for model 10D1422: DN 3 ... DN 1000 (1/10 ... 40"); model 10DI1425 and 10DS3111A-E:
DN 500 ... DN 1000 (20 ... 40")**

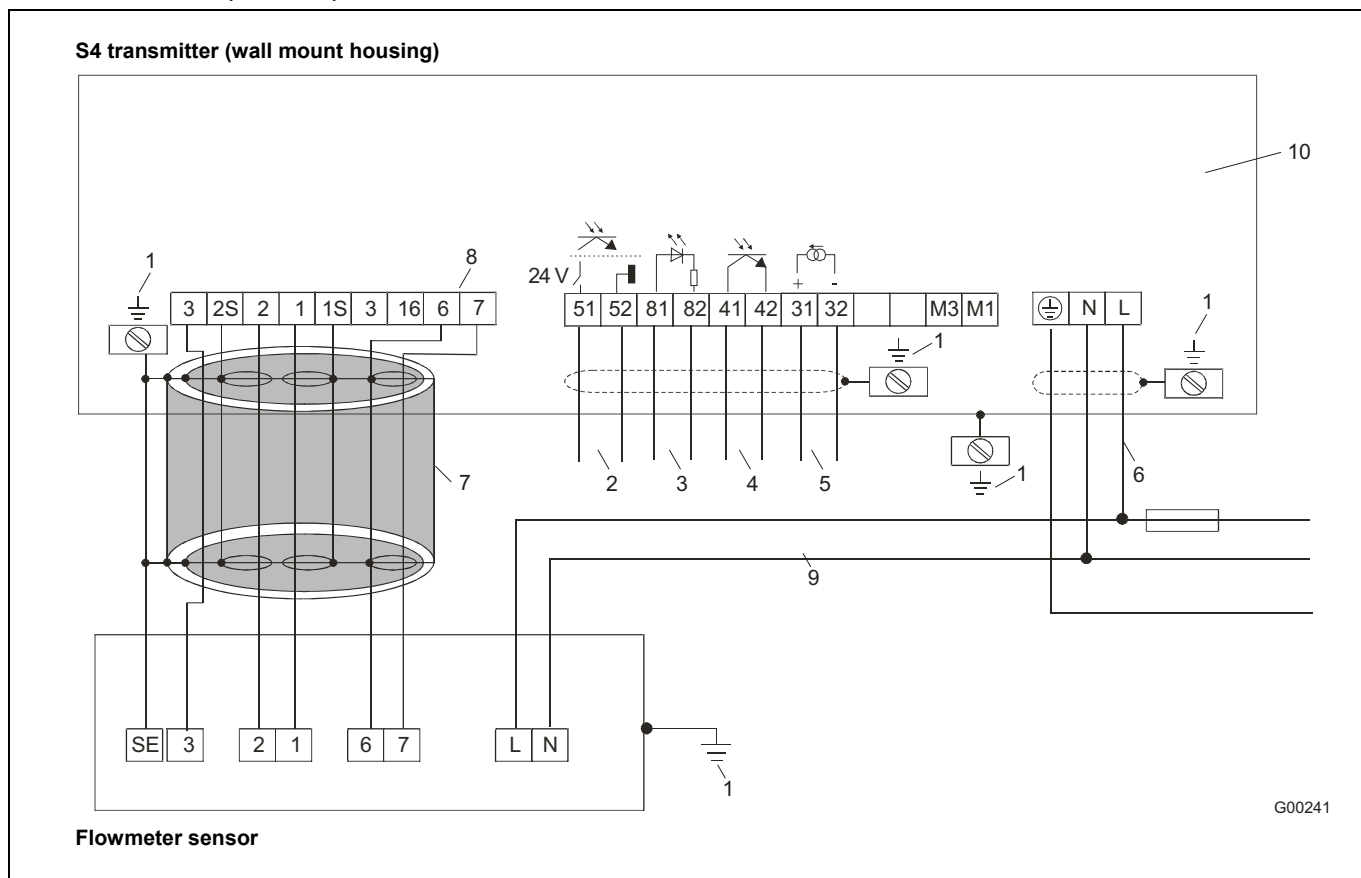

Fig. 43: Flowmeter sensor standard DN 3 ... DN 1000 (1/10 ... 40"), transmitter field-mount housing

- | | |
|---|--|
| <p>1 Functional ground (busbar)</p> <p>2 Pulse output¹⁾</p> <p>3 Contact input¹⁾</p> <p>4 Contact output¹⁾</p> <p>5 Current output¹⁾</p> <p>6 Supply power</p> <p>Low voltage: 100 ... 230 V AC, terminals L, N, ⊕</p> <p>Frequency: 47 Hz ≤ f ≤ 53 Hz; 50 Hz supply power</p> <p>56 Hz ≤ f ≤ 64 Hz; 60 Hz supply power</p> | <p>7 Shielded signal cable: Use ABB order no. D173D025U01 or incorporate in existing wiring</p> <p>8 Reference cable:
Only for connection to model 10D1422
Terminals: close 6,7 and the hook switch S903</p> <p>9 Magnet coil supply:
Magnet coil supply via supply power</p> <p>10 Connection board: D685A1020U03</p> |
|---|--|

1) See the section "Connection examples" in the operating instructions and/or on the data sheet

Comment:

We recommend that shielded output cables be used with the shields connected to the functional ground at one end.

DN 1 ... DN 1000 (1/25 ... 40") with PROFIBUS PA / FOUNDATION Fieldbus

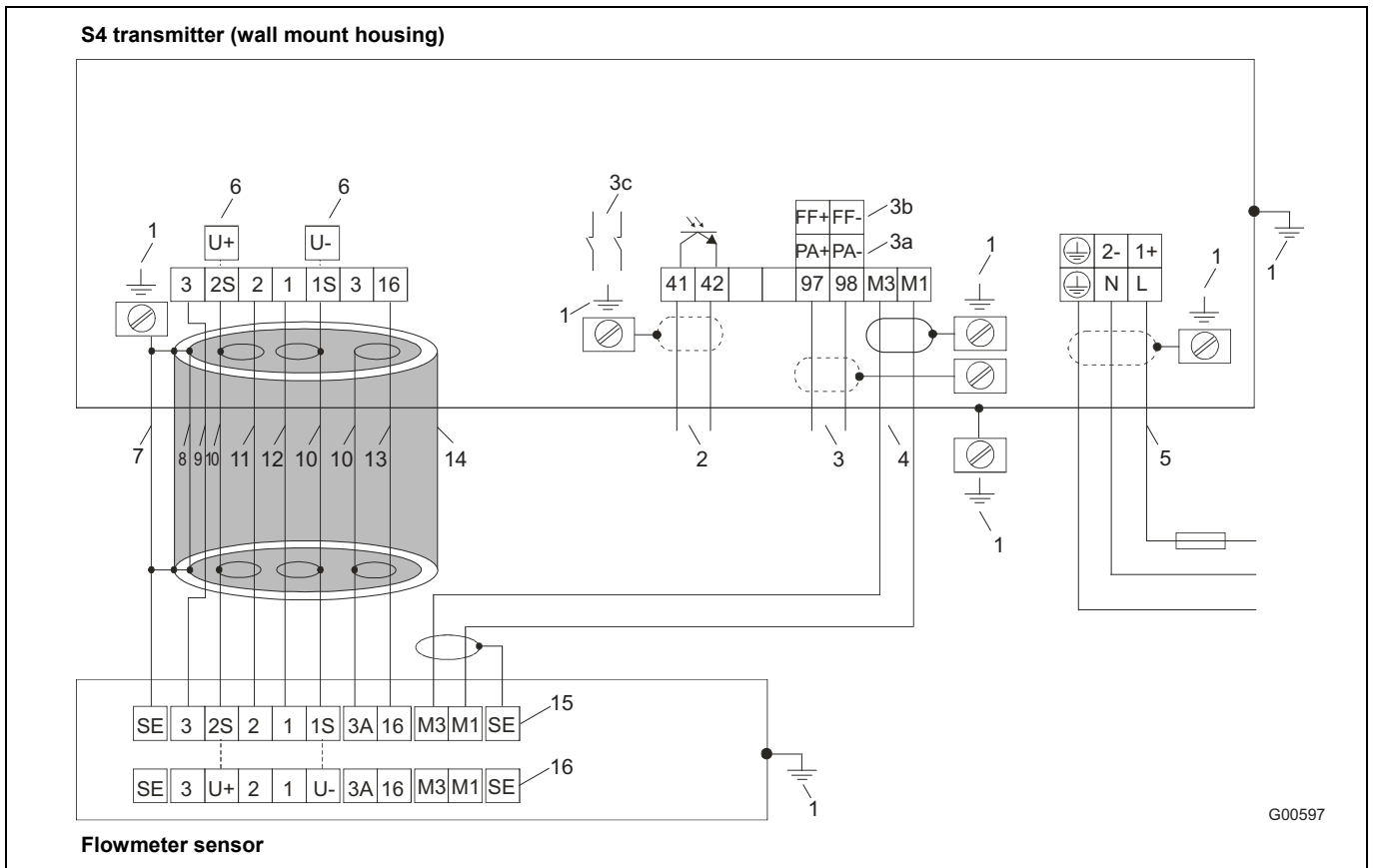

Fig. 44: Connection diagram: transmitter SF with PROFIBUS PA / FOUNDATION Fieldbus

- | | |
|--|---|
| <p>1 Functional ground (busbar)</p> <p>2 Contact output (see the section "Connection examples for peripherals" in the operating instructions and/or on the data sheet)</p> <p>3 Digital communication
 3a: PROFIBUS PA design according to IEC 61158-2 (Profile 3.0)
 U = 9 ... 32 V, I = 10 mA (normal operation)
 I = 13 mA (in the event of error/FDE)
 Terminals: 97/98, PA+/PA-
 (see the section "Connecting via M12 plug" in the operating instructions and/or on the data sheet)
 3b: FOUNDATION Fieldbus design conforming to IEC 61158-2
 U = 9 ... 32 V, I = 10 mA (normal operation)
 I = 13 mA (in the event of error/FDE)
 Terminals: 97/98, FF+/FF-
 (see the section "Connecting via M12 plug" in the operating instructions and/or on the data sheet)
 3c: Bus termination with installed bus termination components with hook switches closed</p> <p>4 Magnet coil cable:
 shielded 2 x 1 mm² CE Typ 227 TEC 74
 ABB order no. D173D147U01, 10 m included in shipment, standard</p> | <p>5 Supply power
 Low voltage: 100 ... 230 V AC, terminals L, N, ⊕
 Low voltage: 20.4 ... 26.4 V AC;
 20.4 ... 31.2 V DC
 Terminals 1+, 2-, ⊕
 Frequency: 47 Hz ≤ f ≤ 53 Hz; 50 Hz supply power
 56 Hz ≤ f ≤ 64 Hz; 60 Hz supply power</p> <p>6 Shielded signal cable:
 Power supply for flowmeter sensor with preamplifier
 Terminals U+, U- instead of 2S and 1S in standard unit</p> <p>7 Steel shielding</p> <p>8 Aluminum foil</p> <p>9 Yellow</p> <p>10 Shield</p> <p>11 Blue</p> <p>12 Red</p> <p>13 White</p> <p>14 Shielded signal cable: ABB order no. D173D025U01, 10 m, included in shipment</p> <p>15 Without preamplifier</p> <p>16 With preamplifier (always with DN 1 ... DN 8 [1/25 ... 5/16"])</p> |
|--|---|

Comment:

We recommend that shielded output cables be used with the shields connected to the functional ground at one end.



Important

If the flowmeter sensor is equipped with a preamplifier for low conductivity or in nominal diameter DN 1 ... DN 8 (1/25 ... 5/16"), the shieldings of the signal wires must be connected to terminals U+ and U- on both the flowmeter sensor and the transmitter.

6.5 Connection examples for peripherals (incl. HART)

Current output

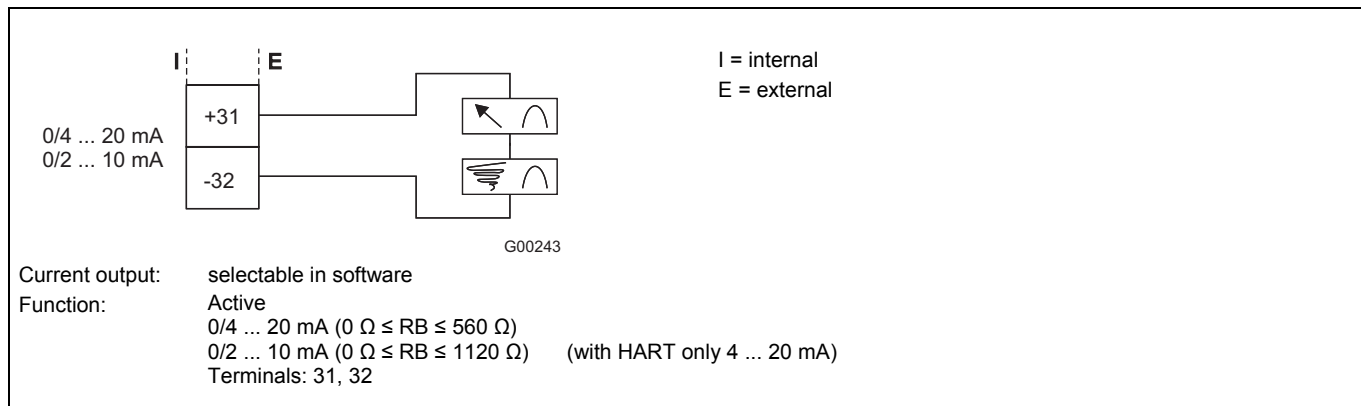

Fig. 45: Current output active with/without HART protocol (4 ... 20 mA)

Contact output

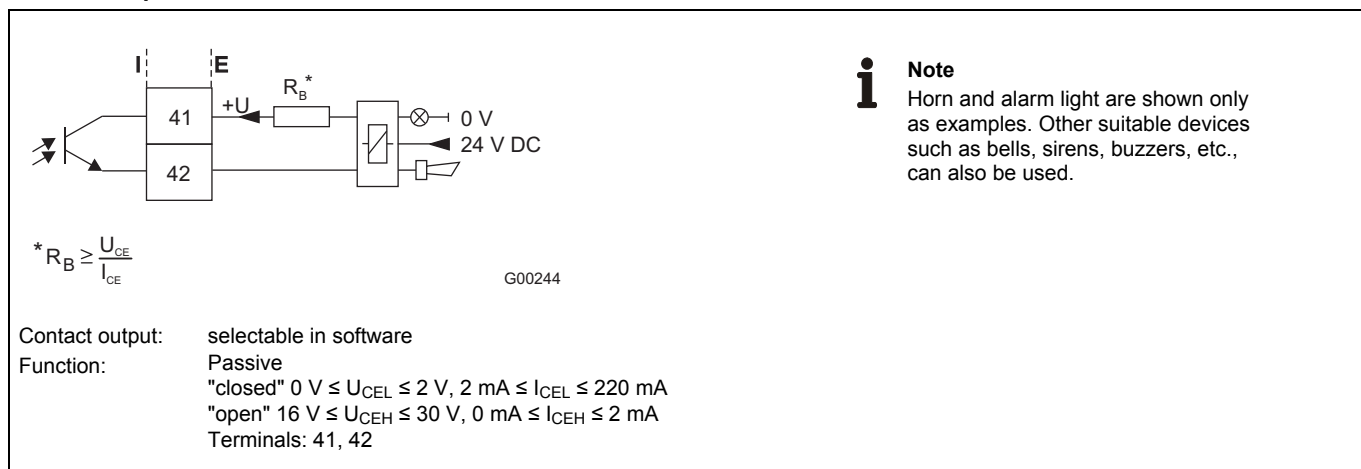

Fig. 46: Contact output for system monitoring, Max.-Min. alarm for empty tube or forward/reverse signal

Contact input

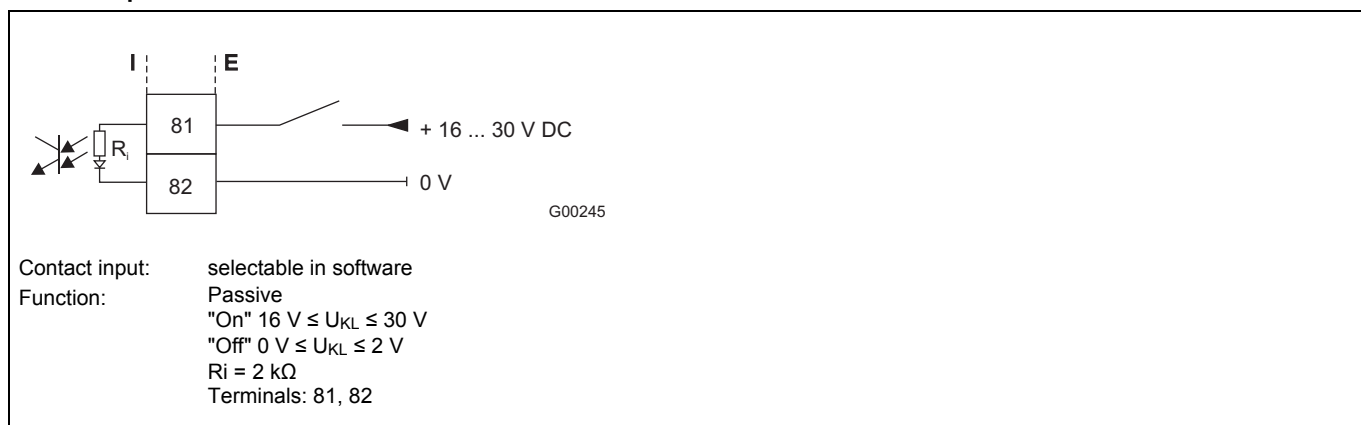

Fig. 47: Contact input for external totalizer reset and external zero return

Pulse output

Pulse output active

G00598

Pulse output, passive, optocoupler

G00247

* $R_B \geq \frac{U_{CE}}{I_{CE}}$

Function: active/passive, selectable via jumper (see "Commissioning" in operating instructions)

fmax: 5 kHz,

fmin: 0.00016 Hz

Setting range: Pulses/unit, pulse width (observe dynamic limits)

Active: 150 Ω ≤ Load < 10 kΩ Pulse width ≤ 50 ms, max. pulse frequency ≤ 3 Hz,
 500 Ω ≤ Load < 10 kΩ Pulse width ≥ 0.1 ms, max. pulse frequency: 5 kHz

Passive: "closed": 0 V ≤ U_{CEL} ≤ 2 V, 2 mA ≤ I_{CEL} ≤ 220 mA
 "open": 16 V ≤ U_{CEH} ≤ 30 V, 0 mA ≤ I_{CEH} ≤ 2 mA

Terminals: 51, 52

Fig. 48: Pulse output, active and passive, optocoupler

PROFIBUS PA / FOUNDATION Fieldbus

G00248

The resistance R and capacitor C form the bus termination. They must be installed when the device is connected to the end of the entire bus cable.

R = 100 Ω; C = 1 μF

1 PROFIBUS PA
 2 FOUNDATION Fieldbus

I = Internal
 E = external

Fig. 49

Bus termination for S4 transmitter

To terminate the bus if the instrument is at the end of the bus cable, the termination components in the S4 transmitter can be used. To do so, close both hook switches in the connection area of the transmitter.



Important

If the transmitter plug-in module is removed, bus termination is also canceled.

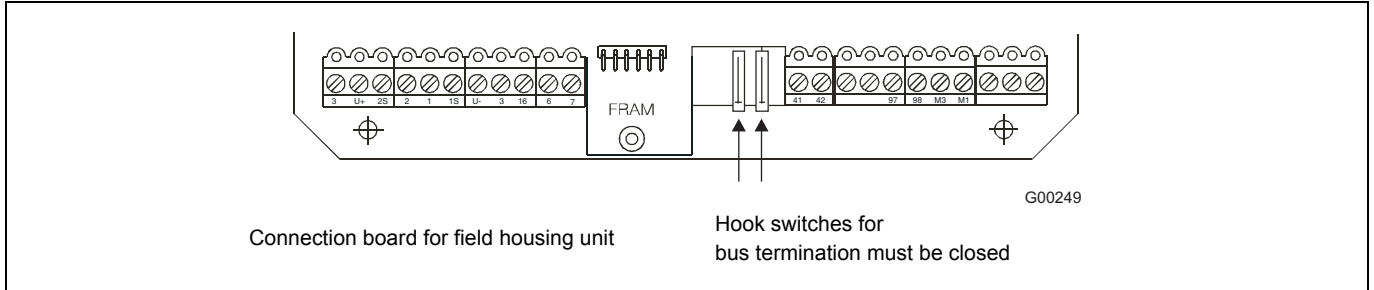

Fig. 50

Connection via M12 plug (for PROFIBUS PA only)

As an option, the bus can also be connected via an M12 plug instead of the cable gland (see order information for device). The device can be shipped completely prewired. For information about suitable connectors (type EPG300) and other accessories, refer to the data sheet 10/63.6.44 DE.

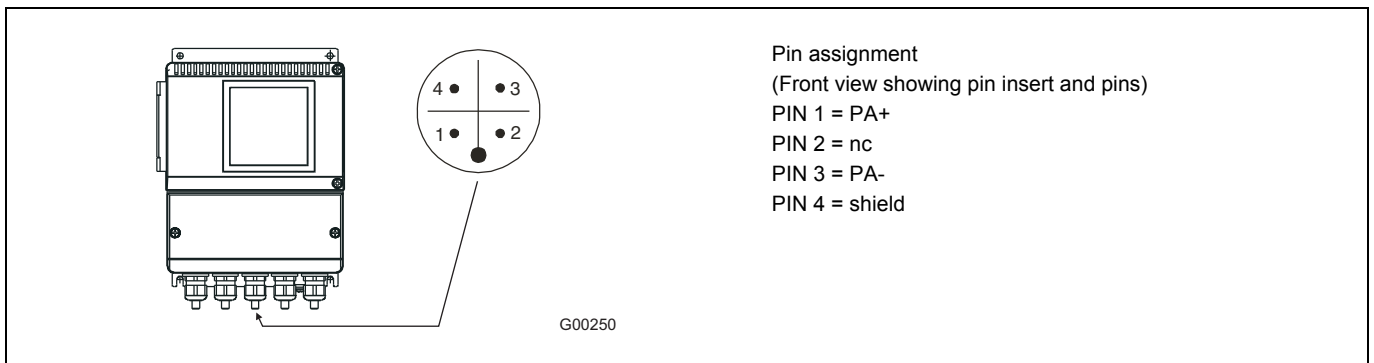

Fig. 51

6.6 Dimensions

6.6.1 Transmitter housing and mounting arrangements

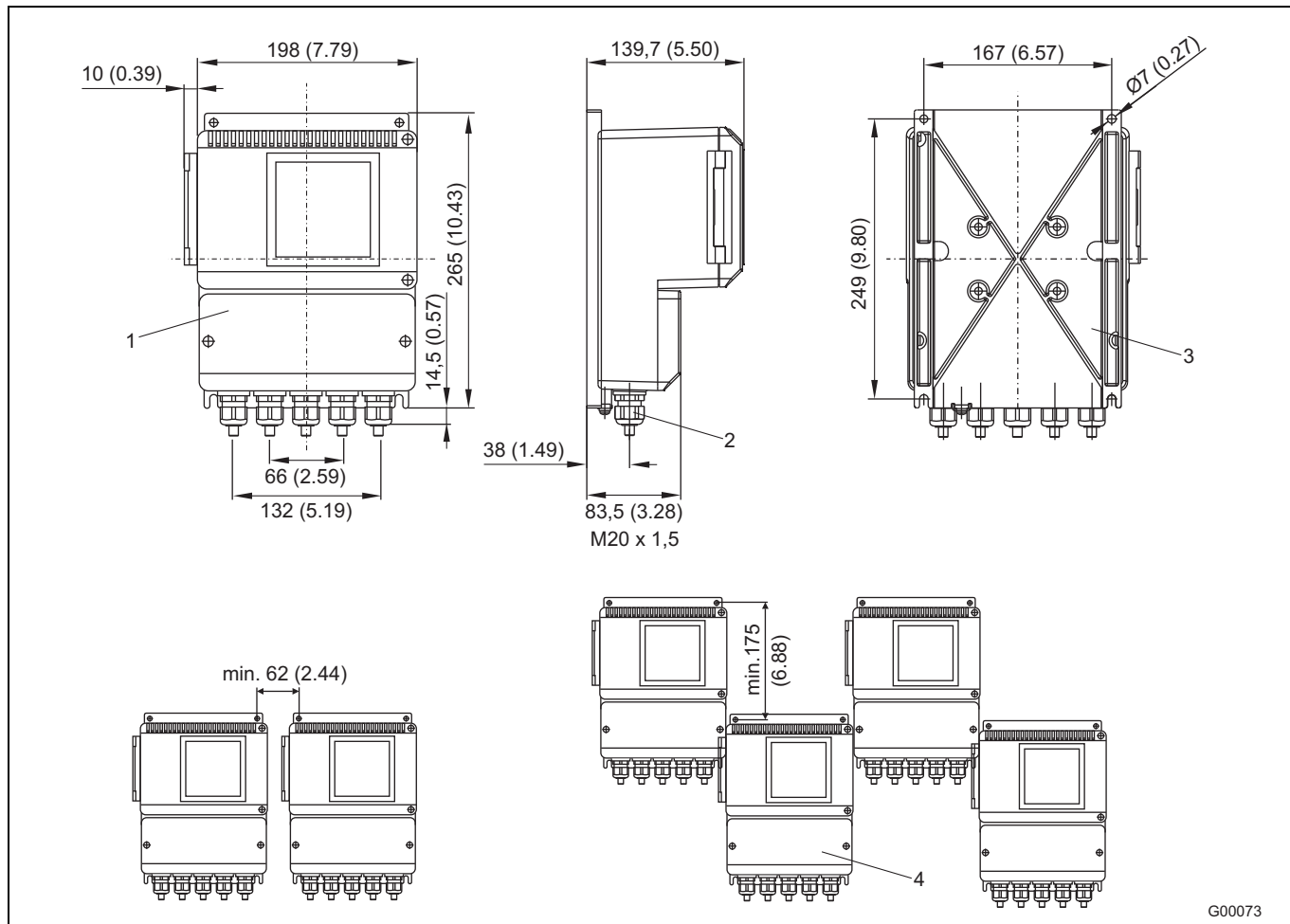

Fig. 52: (Dimensions in mm)

- 1 Field mount housing with window
- 2 Cable connector M20 x 1.5
- 3 Mounting holes for pipe mounting set for a 2" – pipe installation; mounting set upon request (order no. 612B091U07)
- 4 Protection class IP 67

6.7 Ordering information

Accuracy 0.5% of rate

Version number	Main order number														Add. order no.
	1-3	4	5	6	7	8	9	10	11	12	13	14			
FSM4000-S4 External Converter	S4-	X	X	X	X	X	X	X	X	X	X	X	X	X	XX
Housing															
Field housing (cable gland M20 x 1.5)		A													
Field housing (cable gland 1/2 in. NPT)		B													
Power Supply															
100 ... 230 V AC				G											
16.8 ... 26.4 V AC / 16.8 ... 31.2 V DC				K											
Display															
Magnetic stick operation and display illuminated				A											
Input / Output Options															
Current output active + Pulse output active + Contact input + Contact output					1)	0	1								
Current output active + Pulse output active + Contact input + Contact output + HART						0	2								
Current output active + Pulse output passive + Contact input + Contact output					1)	0	3								
Current output active + Pulse output passive + Contact input + Contact output + HART						0	4								
Contact output + PROFIBUS PA						0	7								
Contact output + FOUNDATION Fieldbus						0	8								
Contact output + PROFIBUS PA with M12 plug						1	0								
Others						9	9								
Application															
Extended diagnostics								1							
For Flowmeter Sensor															
SE2_, SE4_									2)	1					
DS2_, DS4_, 10DS3111, 10DI1425 (>= DN 500 [20 in.]), 10D1422, 10D1418, 10D1430									3)	2					
Certificates															
Standard														0	
Name Plate Language / Type															
German / Adhesive foil															G
English / Adhesive foil															E
French / Adhesive foil															F
German / Stainless steel															J
English / Stainless steel															K
French / Stainless steel															L
Design Level / Software Level (Specified by ABB)															
														X	X
Language of Documentation															
German															M1
English															M5
Russian															MB
Language package Western Europe / Scandinavia (Languages DE, EN, DA, ES, FR, IT, NL, PT, FI, SV)															ME
Language package Eastern Europe (Languages DE, EL, CS, ET, LV, LT, HU, PL, SK, SL, RO, BG)															MW
Others															MZ
Other Usage Certifications															
Russia, Metrological and GOST-R Certificate															CG1
Kazakhstan, Metrological and GOST-K Certificate															CG2
Ukraine, Metrological Certificate															CG3
Belarus, Metrological Certificate															CG6

- 1) Not with low voltage power supply (code K)
- 2) The external FRAM is in the terminal box of the associated flowmeter sensor on delivery
- 3) In this variant, the external FRAM already is plugged into the converter with the values Cz = 0 % and Cs = 100 %.

6.8 FXC4000 flowmeter sensor simulator

Main order number

Version number	Main order number					
	1 - 5	6	7	8	9	10
FXC4000 flowmeter sensor simulator	55XC4	X	X	X	X	X
Flow signal setting						
None (adapter only)		0				
3-digit switch in 1,000 increments		1				
Power supply						
Without (adapter only)			0			
With Schuko plug 110 ... 240 V AC 50 / 60 Hz			1			
With 4 mm plug 24 ... 48 V AC / DC			2			
With US plug 110 ... 240 V AC 50 / 60 Hz			3			
Additional equipment						
Without				0		
Adapter for converter type FXE4000-E4, FXM2000-XM2, FXF2000-DF23				1		
Adapter plate for converter FSM4000-S4				5		
Adapter plate for converter FET321				6		
Design level (specified by ABB)						*
Name plate						
German						1
English						2
French						3

6.9 Installation set for 2" pipe installation in field-mount housing



Abb. 53: Part number: 3KXF081100L0001

Contact us

ABB Ltd.

Oldends Lane, Stonehouse
Gloucestershire, GL10 3TA
UK

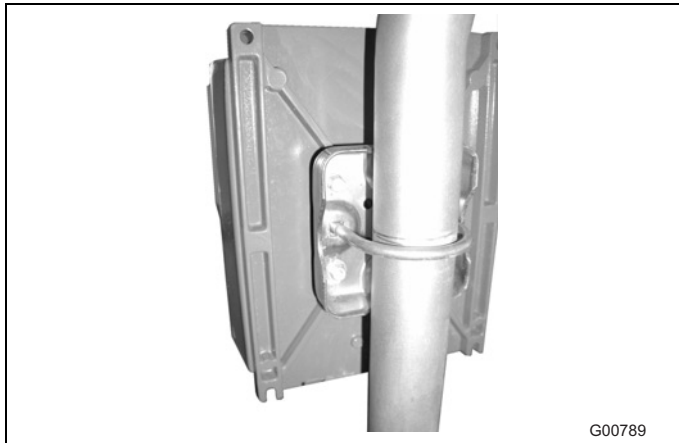
Phone: +44 (0)1453 826661

Fax: +44 (0)1453 829671

ABB Inc.

125 E. County Line Road
Warminster PA 18974
USA

Phone: +1 215 674 6000

Fax: +1 215 674 7183

ABB Automation Products GmbH

Dransfelder Str. 2
37079 Goettingen
Germany

Phone: +49 551 905-534

Fax: +49 551 905-555

www.abb.com

Note

We reserve the right to make technical changes or modify the contents of this document without prior notice. With regard to purchase orders, the agreed particulars shall prevail. ABB does not accept any responsibility whatsoever for potential errors or possible lack of information in this document.

We reserve all rights in this document and in the subject matter and illustrations contained therein. Any reproduction, disclosure to third parties or utilization of its contents - in whole or in parts - is forbidden without prior written consent of ABB.

Copyright© 2010 ABB

All rights reserved