

Guided Wave Radar Bulk Solids Level Transmitter

FEATURES

- Graphic Display with Waveform Screens
- All Digital Electronics
- Radar Signal Travels Along the Waveguide
 - Eliminates False Echoes and Minimizes Signal Loss
- No Moving Parts
- 2 Wire Loop Powered
- Linearization Table
- Lengths From 1 to 100 ft. / 0.3 to 30.6 m
- Flexible Cable Probes



OPTIONS

- HART Protocol
- Glass Viewing Window
- 316L Stainless Steel Enclosure
- MODBUS
- Foundation Fieldbus

ACCESSORIES

- K-COM™ Communications Software
- Loop Indicator

SPECIFICATIONS

Housing	Dual Compartment Powder Coated Aluminum or Stainless Steel
Electrical Connection	1/2" FNPT or M20
Power	13.5 – 36 VDC, Standard; 9 - 32 VDC Foundation Fieldbus; 10 - 18 VDC MODBUS
Wiring	Standard and Foundation Fieldbus - 2 wire
Output	MODBUS - 4 wire plus shield (2 power, 2 data - halfplex) Single 4-20 mA, HART, Foundation Fieldbus (ITK 5.01), MODBUS (RTU or ASCII)
Graphic Display	Field Selectable Units in Feet, Inches, Millimeters, Centimeters, Meters or Percentage and Waveform Screens
Accuracy	+/- 0.20 in / 5.1 mm Direct Mode ; +/- 1.00 in / 25.4mm ULD Mode
Resolution	+/- 0.063 in / 1.6 mm
Range	1 to 100 ft. / 0.3 to 30.6 meters
Sensor Material	316L SS Standard, Monel
Process Pressure	Up to 1500 psi (103 bar)
Process Temperature	Up to 400°F (204°C)
Dielectric Constant	1.3-2.3 ULD Mode ; 3-100 Direct Mode
Approvals	<p>Factory Mutual Research Corporation</p> <p>XP-IS / I / 1 / ABCD / T6 Ta = 77°C</p> <p>DIP / II, III / 1 / EFG / T6 Ta = 77°C</p> <p>IS / I / 1 / ABCD / T4 Ta = 77°C - ELE1034</p> <p>NI / I / 2 / ABCD / T4 Ta = 77°C</p> <p>S / II, III / 2 / FG / T4 Ta = 77°C</p> <p>ANI / I / 2 / ABCD / T4 - ELE1034</p> <p>Type 4X</p> <p>ATEX</p> <p>ITS08ATEX15870X</p> <p>II 1/2 G/D Ex ia d IIC T6</p> <p>Ex tD 20/A21 IP6X T80°C</p> <p>ITS08ATEX25865X</p> <p>II 1/2 G/D Ex ia IIB T4 (-40°C ≤ Tamb ≤ 66°C)</p> <p>Ex iaD 20/21 IP6X T80°C (-40°C ≤ Tamb ≤ 66°C)</p> <p>IEC International Electromechanical Commission</p> <p>IECEX ITS 08.0036X</p> <p>II 1/2 G/D</p> <p>Ex ia IIB T4 (-40°C ≤ Tamb ≤ 66°C)</p> <p>Ex iaD 20/21 IP6X T80°C (-40°C ≤ Tamb ≤ 66°C)</p> <p>IECx ITS 08.0037X</p> <p>Ex ia d IIC T4</p> <p>Ex iaD tD 20/A21 IP6X T80°C</p>



Canadian Standards Association

XP:
CL 1, DIV 1, GP ABCD; CL 2, DIV 1, GP EFG; CL 3 - T6
CL 1, DIV 2, GP ABCD; CL 2, DIV 2, GP EFG - T5

IS:
CL 1, DIV 1, GP CD; CL 2, DIV 1, GP EFG - T4 - when installed per ELE1034

Type 4X



GOST Russian

1Exd[ia]IIC T6, 0ExialIB T6, IP67



UKRSEPRO

1ExdialICT6; 0ExialIB T4



ORDERING INFORMATION

MT5200/a/b/c/d/e/f/g/h/i/j/k:

/a	Probe Material	
	S6	316L Stainless Steel Standard
	MO	Monel
	IN25	Inconel 625
/b	Transmitter Configuration	
	L	Local Transmitter Standard
	LW	Local Transmitter with Window Cover Standard
/c	Transmitter Housing	
	A	Dual Compartment Aluminum Housing Standard
	S	Dual Compartment 316L Stainless Steel Housing
/d	Process Connection / Waveguide Coupler	
	Cxo	x Process Connection & Waveguide Coupler (Table 1 and Table 4)
	o	Seal Code (Table 2)
/e	Probe Type	
	X	None
	Pnn	xx Probe Code (Table 3 and Table 4)
/f	Probe Attachment	
	X	None
	CDyyz-w	Clamp On Centering Disk (Required for ULD Mode)
	CWyyz-ww	Clamp On Centering Weight (Cable Probes)
	OR	
	E	Eyelet
		A Centering Disk and Weights Guide is available under Data Sheets on the MT5200 Product Page on K-TEK's Website (www.ktekcorp.com).
/g	Process Temperature	
	H0	32 to 250°F / 0 to 121°C Maximum
	H6	Above 250°F / 121°C or below 32°F / 0°C
		Electronics enclosure is extended 6" above process connection (Refer to Table 1 for maximum process temperatures)
/h	Electronic Module	
	X	None
	M7A	One Level, Graphic Display , 4-20 mA Output, HART Add suffix "M" for MODBUS (not Intrinsically Safe) Add suffix "F" for Foundation Fieldbus
		  
/i	Approvals	
	X	None
	FM	Factory Mutual Research Corporation and Canadian Standards Association
	GR	GOST Russian (M7AM option not Intrinsically Safe)
	CEX	ATEX Flameproof
	CEI	ATEX I.S.
	IEI	International Electromechanical Commission I.S.
	IEX	International Electromechanical Commission Flameproof
	UKR	Ukraine Sepro
/j	Process Connection	
	P	Standard as shown on Probe Process Connection Table (Table 1)
	FL	Loose flange or plug for use with probe NPT threads Specify type, material & rating from Flange Designation Chart (SLG-0001-1)
	WP	Welded process connection Specify type, material & rating from Flange Designation Chart (SLG-0001-1) The Flange Designation Guide is available under Data Sheets on the MT5200 Product Page on K-TEK Solids Level's Website (www.kteksolidslevel.com) Welded Flanges 400# and above may require the use of an H6 extension.
/k	Length	
	L	Insertion length from face of coupler in inches or millimeters maximum based on probe type
Available Accessories		
	M20 ISO Fitting:	M20 Female Electrical Connection (Brass or Stainless Steel)
	MM	Brass
	MMS	Stainless Steel

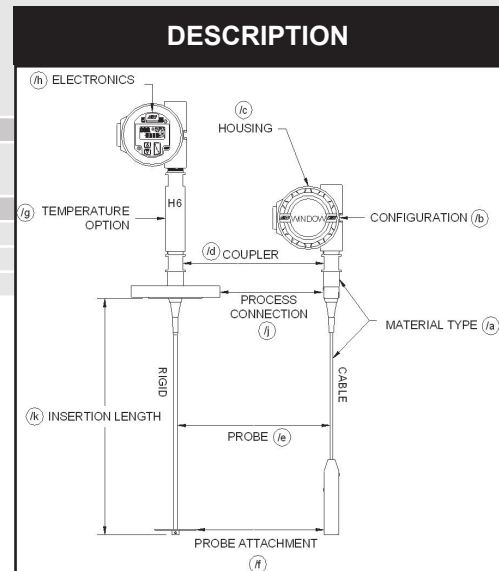

TABLE 1 - PROCESS CONNECTION / WAVEGUIDE COUPLER

Base Code ¹	Insulator	Process Connection	Seal Options Table 2	Maximum Pressure	Maximum Pressure	Max Temp ²	Compatible Probes
C1o	Teflon	3/4" NPT	V, K, E, A	1500psi@100°F / 103bar@38°C 600psi@400°F / 41bar@204°C	-60°F -50°C	400°F 204°C	P11
C2o		1.5" NPT					P12, P33
C3o		2.5"NPT		50 psi@400°F / 204°C			P61, P33
CUSTOM							
CXo	Consult Factory						
Notes:	1. o - Enter seal code from Table 2 (Example: C1V) 2. Consult Table 2 for o-ring temperature specifications.						

Table 2 - O-RING SEALS

Suffix	Description	Min. Temp	Max. Temp	Compatible With	Not Compatible With
V	Viton	-15°F -26°C	400°F 204°C	General Purpose, Ethylene (Liquids & Solids)	Ketones (MEK, Acetone), Skydrol Fluids, Amines, Anhydrous Ammonia, Low Molecular Weight Esters and Ethers, Hot Hydrofluoric or Chlorosulfuric Acids, Sour HCs
K	Kalrez	-40°F -40°C	400°F 204°C	Inorganic and Organic Acids to Include HH and Nitric, Aldehydes, Ethylene, Glycols, Organic Oils, Silicone Oils, Vinegar, Sour HCs, Amines, Ethylene Oxide, Propylene Oxide	Ketones (MEK, Acetone), Skydrol Fluids, Amines, Anhydrous Ammonia, Low Molecular Weight Esters and Ethers, Hot Hydrofluoric or Chlorosulfuric Acids, Sour HCs
E	EPDM	-60°F -50°C	250°F 125°C	Acetone, MEK, Skydrol Fluids, Anhydrous Ammonia	Petroleum Oils, Di-Ester Base Lubricants, Propane
A	Aegis	-14°F -10°C	572°F 300°C	Most Chemicals (Liquids & Solids)	Brake Fluid

TABLE 3 - PROBE TYPE

Code	O.D.	Notes	Max Length	Attachment Options
SINGLE CABLE				
P11	0.19in (5mm)		20ft (6.1m)	CD ¹ , CW, E
P12	0.25in (6mm)		50ft (15.3)	
P61	0.31in (8mm)		50ft (15.3)	
Notes:	1. Required for ULD operating mode			
TRIANGLE CABLE				
P33	0.25in (6mm)	Minimum 4" flange connection required	100 ft (30.6 m)	CW-S6 (Required)
CUSTOM				
PXX	Custom Probe, Consult Factory			

TABLE 4 - COUPLER LOAD SPECIFICATIONS

COUPLER	C1o	C2o	C3o
Bulk Density	lb/ft ³ < 25 kg/m ³ < 400	lb/ft ³ < 25 kg/m ³ < 400	lb/ft ³ < 50 kg/m ³ < 801
Maximum Cable Loading	2,000 lbs 907 kg	2,000 907 kg	10,000 lbs 4536 kg



Information regarding bulk densities of solids may be found at the following web addresses:

- http://www.simetric.co.uk/si_materials.htm
- http://www.powderandbulk.com/resources/bulk_density/material_bulk_density_chart_a.htm

MT5200 Recommended Installation

NOTE: The following guidelines are very conservative. If you have an application that exceeds these limits consult factory for application recommendations.

1. SINGLE PROBE				
Operating Mode	MINIMUM DIELECTRIC CONSTANT	MAXIMUM PROBE LENGTH ²	L1 Unmeasurable ¹	L2 Unmeasurable ¹ (WH = Weight Height)
ULD ³	1.3 - 2	50 ft. / 30.5 m	0 in. / 0 cm	0
Direct	5	20 ft. / 6.1 m	6 in. / 15.2 cm	WH + 3 in. / 7.6 cm
	10	40 ft. / 12.2 m	3 in. / 7.5 cm	WH + 3" / 7.6 cm
	35	50 ft. / 30.5 m	0 ¹ in. / 0 ¹ cm	0 ¹

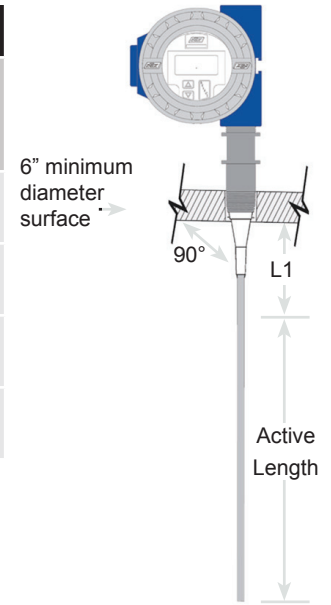

NOTES:

1. L1 & L2 unmeasurable lengths of 0 may require use of linearization table and latching feature. For easiest startup use $L1_{min} \geq 3"$ or $WH + 3"$.
2. Maximum probe lengths are limited as indicated in Table 2A.
3. Ultra-Low Dielectric (ULD) measurement method. Accuracy subject to changes in dielectric constant. Requires use of 2.75 inch min. centering disk.

2. TRIANGLE PROBE			
MINIMUM DIELECTRIC CONSTANT	L MAXIMUM PROBE LENGTH ²	L1 Unmeasurable ¹	L2 Unmeasurable ¹
3	20 ft. / 6.1 m	6 in. / 15.2 cm	5 in. / 12.7 cm
4	20 ft. / 6.1 m	3 in. / 7.5 cm	5 in. / 12.7 cm
10	50 ft. / 30.5 m	0 ¹ in. / 0 ¹ cm	2 ¹

NOTES:

1. L1 & L2 unmeasurable lengths of 0 may require use of linearization table and latching feature. For easiest startup use $L1_{min} \geq 3"$ or as listed if greater and $L2_{min} \geq 5"$
2. Maximum probe lengths are limited as indicated in Table 2A.

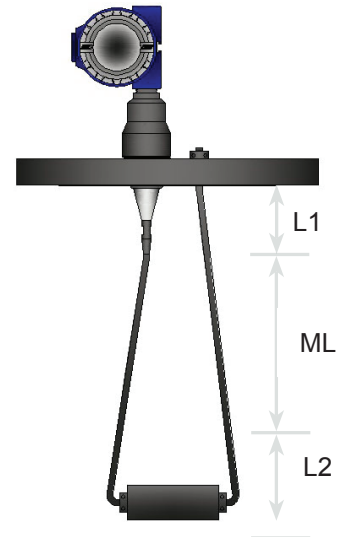

MT5200 Guided Wave Radar Probe Attachments

MT5200 Guided Wave Radar Probe Attachments					
Part No.	Material	O.D.	Weight Height (WH)	Weight	Compatible Probes
CW09D-S6	316SS	0.875 in. / 22.2 mm	4.0 in. / 101.6 mm	0.7 lbs / 301 g	P11
CW09D-MO	Monel			0.8 lbs / 324 g	
CW10D-S6	316SS	1.0 in. / 25.4 mm	6.0 in. / 152.4 mm	1.3 lbs / 590 g	P11
CW10D-MO	Monel			1.4 lbs / 635 g	
CW10E-S6	316SS			1.3 lbs / 590 g	P12
CW10E-MO	Monel			1.4 lbs / 635 g	
CW16F-S6	316SS	1.625 in. / 41.3 mm	2.0 in. / 50.8 mm	1.1 lbs / 499 g	P11 ¹ , P31
CW16F-MO	Monel			1.2 lbs / 544 g	
CW19G-S6	316SS	1.875 in. / 47.6 mm	2.0 in. / 50.8 mm	1.5 lbs / 680 g	P12 ¹ , P32
CW19G-MO	Monel			1.6 lbs / 726 g	
CW29F-S6	316SS	2.875 in. / 73.3 mm	1.0 in. / 25.4 mm	1.8 lbs / 816 g	P11 ¹ , P31
CW29F-MO	Monel			2.0 lbs / 907 g	
CW29G-S6	316SS			1.8 lbs / 816 g	P12 ¹ , P32
CW29G-MO	Monel			2.0 lbs / 907 g	
CW29H-S6	316SS	1.5 in. / 38.1 mm	5.25 in. / 133.35 mm	2.2 lbs / 998 g	P61 ¹
CW-S6	316SS	2 in. / 50.8 mm	6 in./152.4 mm Long		P33 only

Centering Disks

Part No.	O.D.	Height	Compatible Probes
CD38A-S6	3.75 in. / 95.3 mm	0.0625 in / 1.5 mm	P11 ¹ , P12 ¹
CD60A-S6	4.00 in. / 101.6 mm	0.5 in / 12.7 mm	P61 ¹

¹ULD Mode requires a weight and centering disk assembly for all installations.



ULD Mode - weight and disc assembly

Quotation Request - MT5200 SERIES Guided Wave Radar

Tel (1) 225-673-6100 Email:sales@ktekcorp.com Date: _____

Fax (1) 225-673-2525 Attn: _____

Customer: _____	Contact: _____
Phone #: _____	Fax #: _____
Email: _____	Project: _____
Rep Firm: _____	Contact: _____
Phone #: _____	Fax #: _____
Email: _____	

Process Conditions: TAG: _____

Material to be Measured: _____ Dielectric Constant: _____

Is Material: Solid (Refer to MT5200 Bulk Solids Level Transmitter Data Sheet (MT5200-0202-1) for more information).





Particle Diameter: _____ Bulk Density: _____ pcf kg m³

Temperature: Operating: _____ Maximum: _____ °F °C °K

Pressure: Operating: _____ Maximum: _____ PSIG KG BAR

Buildup: None Light Heavy
None

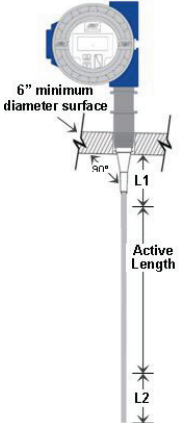
Choose all that apply:

<input type="checkbox"/> C1 Coupler Bulk Density: lb/ft ³ < 25 / kg/m ³ < 400 Maximum Cable Loading: 2,000 lbs / 907 kg 	<input type="checkbox"/> C2 Coupler Bulk Density: lb/ft ³ < 25 / kg/m ³ < 400 Maximum Cable Loading: 2,000 lbs / 907 kg 	<input type="checkbox"/> C3 Coupler Bulk Density: lb/ft ³ < 50 / kg/m ³ < 801 Maximum Cable Loading: 10,000 lbs/4536 kg 																	
<input type="checkbox"/> Single Probe <table border="0"> <tr> <td>Minimum Dielectric Constant</td> <td>Maximum Probe Length</td> </tr> <tr> <td>1.3-2</td> <td>50 ft. / 30.5 m</td> </tr> <tr> <td>5</td> <td>20 ft. / 6.1 m</td> </tr> <tr> <td>10</td> <td>40 ft. / 12.2 m</td> </tr> <tr> <td>35</td> <td>50 ft. / 30.5 m</td> </tr> </table> 	Minimum Dielectric Constant	Maximum Probe Length	1.3-2	50 ft. / 30.5 m	5	20 ft. / 6.1 m	10	40 ft. / 12.2 m	35	50 ft. / 30.5 m	<input type="checkbox"/> Triangle Probe <table border="0"> <tr> <td>Minimum Dielectric Constant</td> <td>Maximum Probe Length</td> </tr> <tr> <td>3</td> <td>20 ft. / 6.1 m</td> </tr> <tr> <td>4</td> <td>50 ft. / 30.5 m</td> </tr> <tr> <td>10</td> <td>100 ft. / 60 m</td> </tr> </table> 	Minimum Dielectric Constant	Maximum Probe Length	3	20 ft. / 6.1 m	4	50 ft. / 30.5 m	10	100 ft. / 60 m
Minimum Dielectric Constant	Maximum Probe Length																		
1.3-2	50 ft. / 30.5 m																		
5	20 ft. / 6.1 m																		
10	40 ft. / 12.2 m																		
35	50 ft. / 30.5 m																		
Minimum Dielectric Constant	Maximum Probe Length																		
3	20 ft. / 6.1 m																		
4	50 ft. / 30.5 m																		
10	100 ft. / 60 m																		

1. Accuracy subject to changes in dielectric constant. Ultra-Low Dielectric (ULD) measurement method supports dielectric constants from 1.3 to a maximum of 2.5.

Quotation Request

Material & Connections:

Process Connection: MNPT RF Flange Tri-Clamp Other

Process Connection Description: _____

Probe Material: 316L SS Hast C276 Hast B3 Monel Titanium Inconel 625

Probe Type: Solid Rod Cable (316SS & Monel Only) Sanitary Rod Specify Finish

180 Grit 240 Grit & EP (Refer to chart for part numbers)

Centering Disk: Yes No P/N: _____ If blank, K-TEK will choose.

Centering Weight (Cables): Yes No P/N: _____ If blank, K-TEK will choose.

Housing & Electronics Options:

Aluminum Dual Compartment Housing (standard) 316L SS Dual Compartment Housing

Window Cover HART MODBUS Foundation Fieldbus

Host: _____

Vessel / Application Details:

Total Insertion Length (Bottom of process fitting to end of probe): _____ in. ft. cm m Other

Standard Lengths for field modification to final length: _____

Custom Lengths for final length by K-TEK: _____

Mounting:

Directly on roof of tank _____ Mounted on Nozzle: nozzle height: _____ Diameter: _____

In existing stilling well - describe: _____

In new stilling well - describe: _____

In external chamber - describe: _____

Stilling well or external chamber to be supplied with transmitter: Yes No

Approval Required:

FM Factory Mutual

XP-IS / I / 1 ABCD / T6; Ta=77°C
DIP / II, III / 1 / EFG / T6; Ta=77°C
IS / I / 1 / ABCD / T4; Ta=77°C - ELE1034
NI / I / 2 / ABCD / T4; Ta=77°C
S / II, III / 2 / FG / T4; Ta=77°C
ANI / I / 2 / ABCD / T4 - ELE1034
TYPE 4X

GOST - Russian

Flameproof: 1Exd{ia}IIC T6
Intrinsically Safe: 0ExialIBT6;
Ingress Protection: IP67

UKRSEPRO

1ExdialICT6; 0ExialIBT40

Canadian Standards Association

XP CL 1, DIV 1, GP ABCD; CL 2, DIV 1, GP EFG; CL 3 - T6
CL 1, DIV 2, GP ABCD, CL 2, DIV 2, GP EFG - T5
IS CL 1, DIV 1, GP CD; CL 2, DIV 1, GP EFG - T4 - when
installed per ELE 1034
Type 4X

ATEX

Intrinsic Safety: ExialIBT4 (-40°C ≤ Tamb ≤ 66°C), ExiaD20/21
IP6X T80°C (-40°C ≤ Tamb ≤ 66°C)
Flameproof Safety: II 1/2 G/D Exia d IIC T6, ExtD 20/A21 IP6X
T80°C

IEC International Electromechanical Commission

IECEx ITS 08.0036X: II 1/2 G/D, ExialIBT4 (-40°C ≤ Tamb ≤
66°C), ExiaD20/21IP6XT80°C (-40°C ≤ 66°C)
IECx ITS 08.0037X: ExiadIIC T4, ExiaDtD 20/A21 IP6X T80°C0

Completed by K-TEK:

Quotation #: _____ By: _____ Date: _____ Qty: _____

Part#: _____ Price: _____ Options: _____

Additional notes or comments: _____

K-TEK
18321 Swamp Road
Prairieville, LA 70769 USA
Phone: +1.225.673.6100
Fax: +1.225.673.2525
Email: sales@ktekcorp.com
Website: www.ktekcorp.com

MT5200-0202-1 Rev j (07-2010)
DCN0494
For the latest version of this data sheet,
visit ktekcorp.com.

